

Item	Reference	Cat.No.	Remarks
SELECTED lamp	SWD	10844	No switch incorporated
Lens cap, yellow	-	10842	For SELECTED lamp
OFF switch/lamp	SWA	10838	
Lens cap, red	-	10839	For OFF lamp
ON switch/lamp	SWB	10838	
Lens cap, green	-	10840	For ON lamp
RESET switch	SWC	10838	Lamp section not used
Lens cap, white	-	11011	For RESET switch
Bulb, 6V - 0, 2A	-	11388	Used in SELECTED, ON and OFF lamps
ENGINEER'S CONTROL PANEL			
Terminal Block	TBA, B, C, D	11860	
Relay, Varley 4CO - 6V - ON LINE/TEST/PULSE switch	RLA, B.	12218	
OSC. STOP/CYCLE STOP/CYCLE REPEAT switch	SWE	9296	3 posn. key switch, non-locking in PULSE position.
Key, handle	-	7664)	
Insert, black	-	7672)	For SWE and SWF
ENTRY PANEL			
Fuse, 10A	FS1	2931	
Fuseholder, 10A	-	5323	
Plug, 3 way, 20A	PLD	12591	
MAIN ASSY			
Power Unit	PU1	14343	PS461-6V, 6A stabilized
Power Unit	PU2	14057	PS453-6V, 2A stabilized
R. F. filter unit	FL1	11244	2.5A single phase

Board Type	Board Cat. No.	Board Position	L.S.A. AREA REFERENCE														Additional Components					
			1A	1B	2A	2B	3A	3B	4A	4B	5A	5B	6A	6B	7A	7B	G Area Pad Location	Value	To %	Cat. No.		
DPS 194	1(2/4)B25728	B 1	-	01	01	01	01	01	01	01	01	15	15	06	-	46	49	e/25, b/23, c/24	Transistor	-	9727 (P5204)	
																		30/34	Crystal	-	14663	
																			22/23	820Ω	5	11280
																			27/28	220Ω	5	9204
																			29/30, 31/32, 33/34	1K	5	9159
																			11/7	47Ω	5	6396
																			24/5B11	10μF	20	9137
																			14/20	100μF	20	12271
																21/17, 17/13	0.68μF	5	9430			
DP 195	1(2/4)B25729	B 3	-	15	12	03	12	03	12	03	12	03	12	03	06	06	23/27, 33/29	0.68μF	5	9430		
DP 196	1(2/4)B25730	B 4	-	-	-	03	06	-	01	03	01	15	-	-	-							
DP 197	1(2/4)B25731	B 5	-	02	11	02	11	02	06	03	06	03	01	03	01	03	1/2, 3/4, 5/6, 11/12, 13/14, 25/26	47Ω	5	9219		
DP 198	1(2/4)B25732	B 6	-	06	06	06	06	06	05	06	01	06	06	06	-	-						
DP 199	1(2/4)B25733	B 8	02	-	06	06	03	05	03	01	11	12	02	06	01	15	21/22, 23/24, 25/26	47Ω	5	9219		
DP 300	1(2/4)B25734	B 9	03	02	03	06	05	02	06	03	06	02	06	15	06	02						
DP 301	1(2/4)B25735	B 10	46	46	01	01	06	05	02	02	02	15	02	15	-	15	1/2, 3/4	220Ω	5	9204		
DP 302	1(2/4)B25736	B12-B17	06	06	06	03	01	05	06	05	06	05	01	01	11	12						
DP 303	1(2/4)B25737	B18	15	06	15	02	15	05	15	06	15	05	15	02	15	-	15/20, 27/32	1k	5	9159		
DP 304	1(2/4)B25738	B 20	01	01	02	01	03	01	03	12	01	12	15	12	15	01						
DP 305	1(2/4)B25739	B 21	01	46	01	46	01	46	01	46	01	46	01	46	-	46	3/4, 5/6, 7/8, 17/18, 23/24, 29/30, 31/32	220Ω	5	9204		
DP 306	1(2/4)B25740	B 22	-	-	06	06	06	06	02	06	02	06	02	06	01	12						
DP 307	1(2/4)B25741	B 24	01	01	02	06	01	06	11	06	11	06	02	06	11	06	17/18, 19/20, 21/22, 23/24, 25/26, 27/28, 29/30, 31/32, 33/34	47Ω	5	9219		
DP 308	1(2/4)B25742	B 25	02	06	05	02	06	05	01	06	02	11	02	05	15	15	19/20, 21/22, 23/24	47Ω	5	9219		
DP 309	1(2/4)B25743	A 1	03	01	01	01	01	01	02	06	01	02	15	06	06	06	1/2, 3/4, 5/6, 7/8, 9/10, 11/12, 13/14, 15/16	1k	5	9159		
DP 310	1(2/4)B25744	A 4	46	46	46	46	15	46	15	46	15	46	01	46	01	15	1/2, 3/4, 5/6, 7/8, 11/12, 13/14, 23/24, 29/30	220Ω	5	9204		
DP 311	1(2/4)B25745	A 5	-	01	15	15	15	15	01	02	01	03	03	03	01	01						
DP 312	1(2/4)B25746	A 6	03	-	03	01	03	02	03	01	03	01	02	01	01	-						
DP 313	1(2/4)B25747	A7, A8	02	03	01	03	02	03	02	03	01	03	02	03	-	03						
DP 314	1(2/4)B25748	A 9	46	46	46	46	46	46	46	46	46	46	46	46	46	46	1/2, 3/4, 5/6, 7/8, 9/10, 11/12, 13/14, 17/18, 21/22, 23/24, 25/26, 27/28, 29/30, 31/32	220Ω	5	9204		
DP 315	1(2/4)B25749	A11, A12, A14, A17, A19, A20	46	46	46	46	46	46	46	46	46	46	46	46	15	15	1/2, 3/4, 7/8, 9/10, 11/12, 15/16, 17/18, 23/24, 25/26, 29/30, 31/32, 5/6	220Ω	5	9204		
DP 316	1(2/4)B25750	A 13	01	01	01	01	01	03	01	01	03	01	-	-	-	-						
DP 317	1(2/4)B25751	A 18	01	-	01	02	01	01	02	02	01	03	01	01	01	01						
DP 318	1(2/4)B25752	A 21	-	03	01	01	01	01	02	03	01	03	01	01	-	01						
DP 319	1(2/4)B25753	A 23	01	01	06	01	06	01	01	01	01	01	02	01	03	03						
DP 320	1(2/4)B25754	A 24	03	03	01	46	01	46	01	46	03	46	03	46	03	46	4/8, 9/13, 16/20, 21/25, 28/32, 29/33	220Ω	5	9204		

NOTE: On all boards, 3 decoupling capacitors are fitted. These are 10μF ± 20%, Catalogue No. 9137

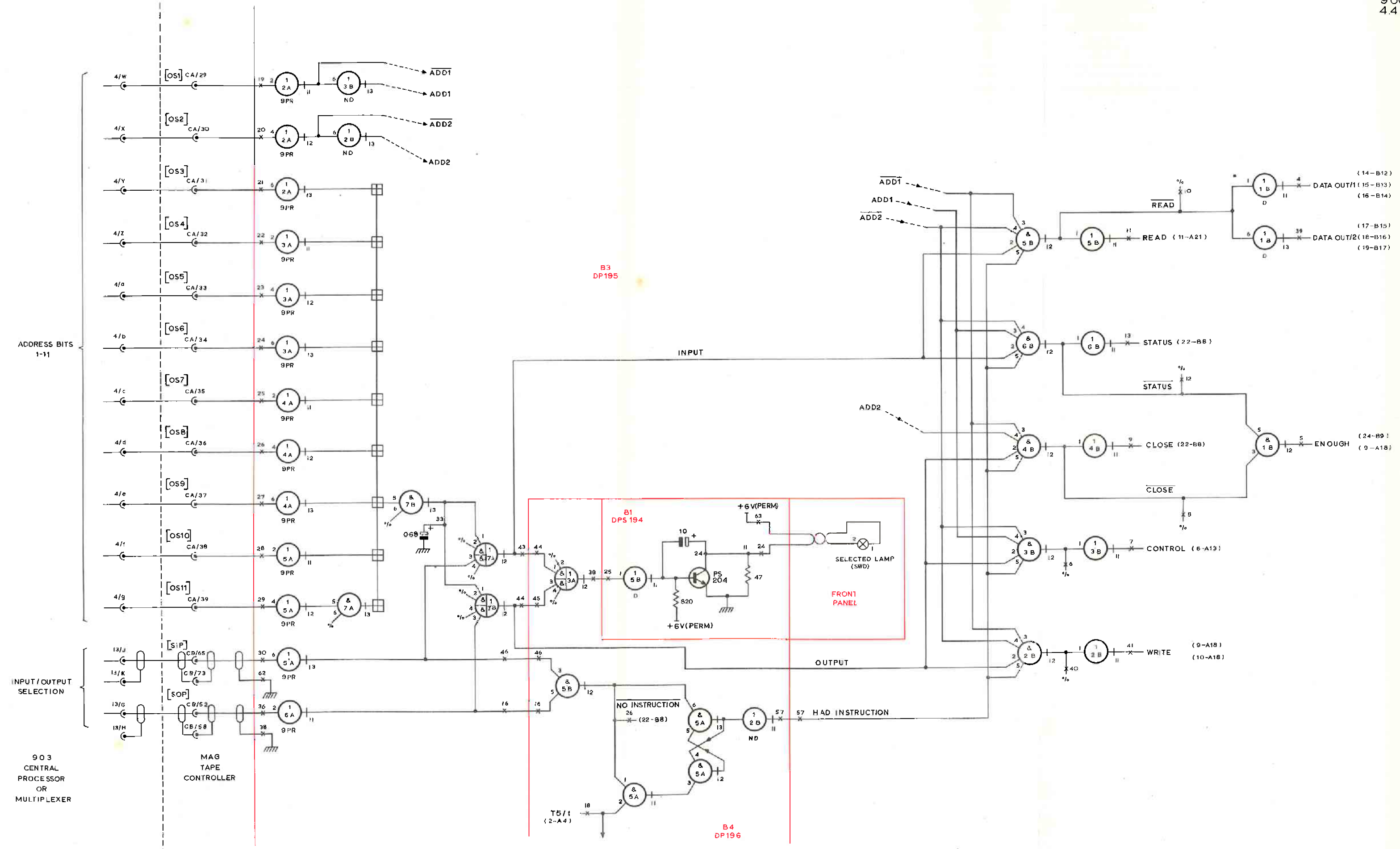

ADDRESS DECODING

Figure 1 (ISSUE 2)

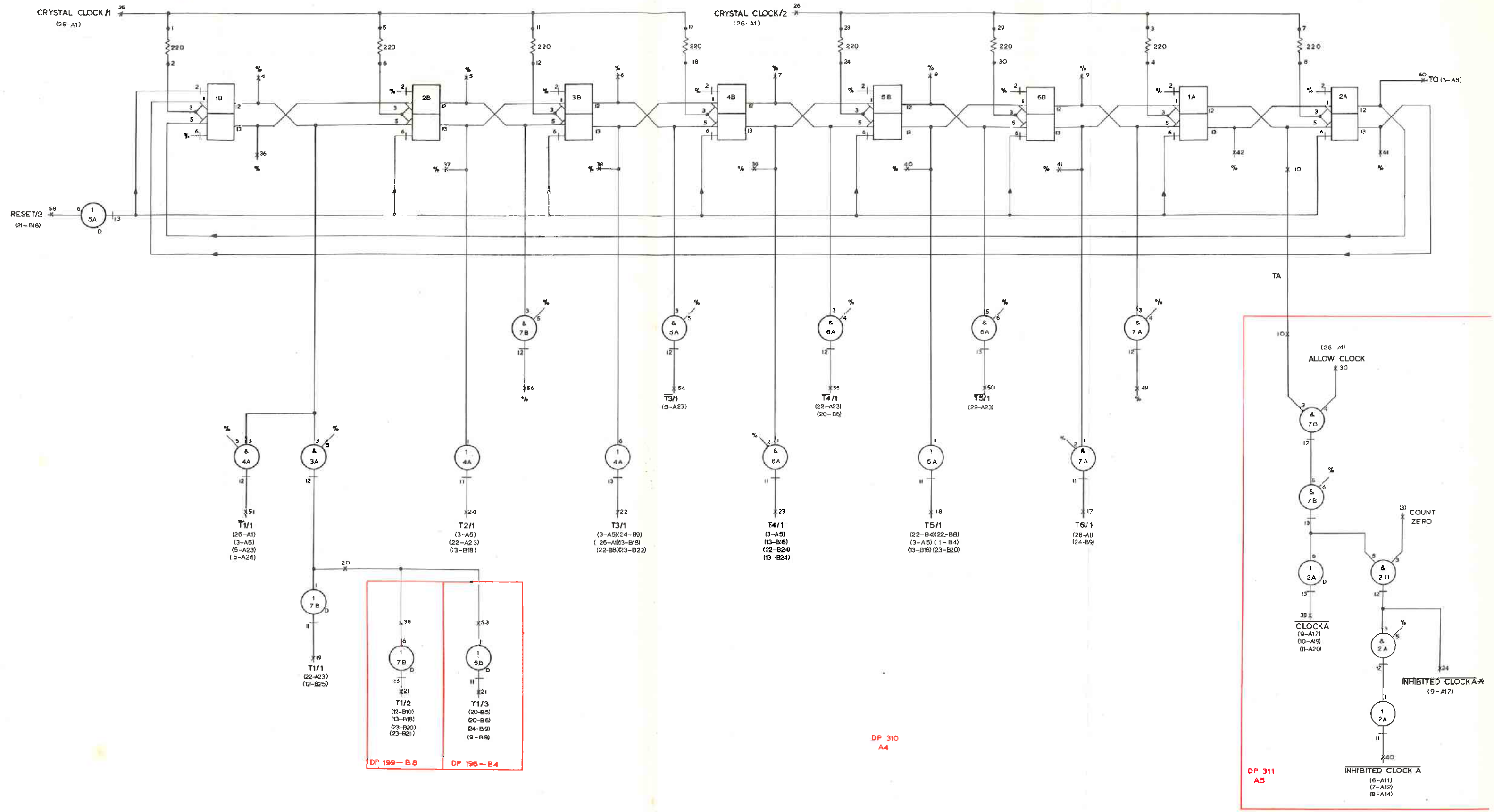

CRYSTAL- CONTROLLED TIMER.

Figure 2 (ISSUE 2)

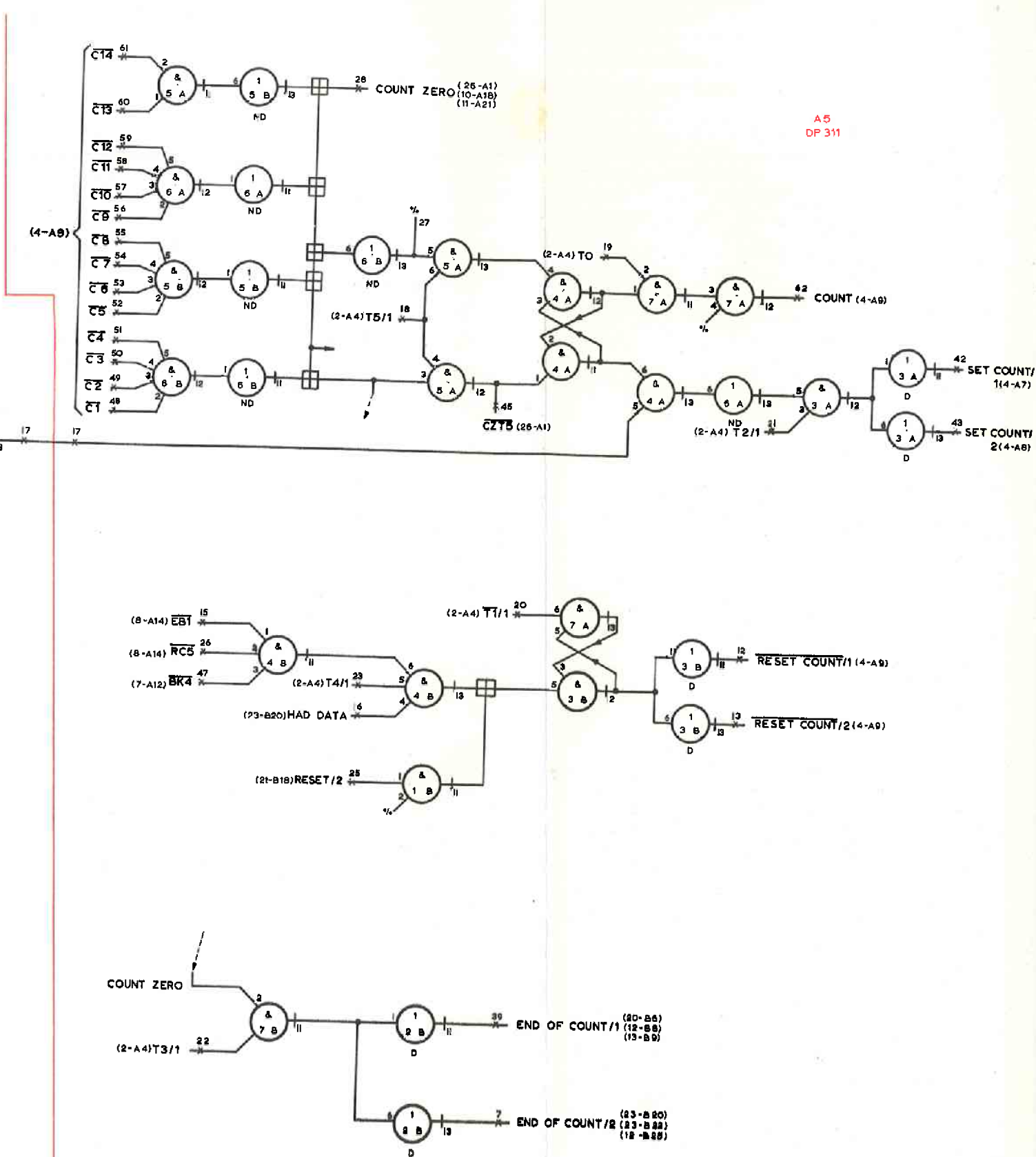
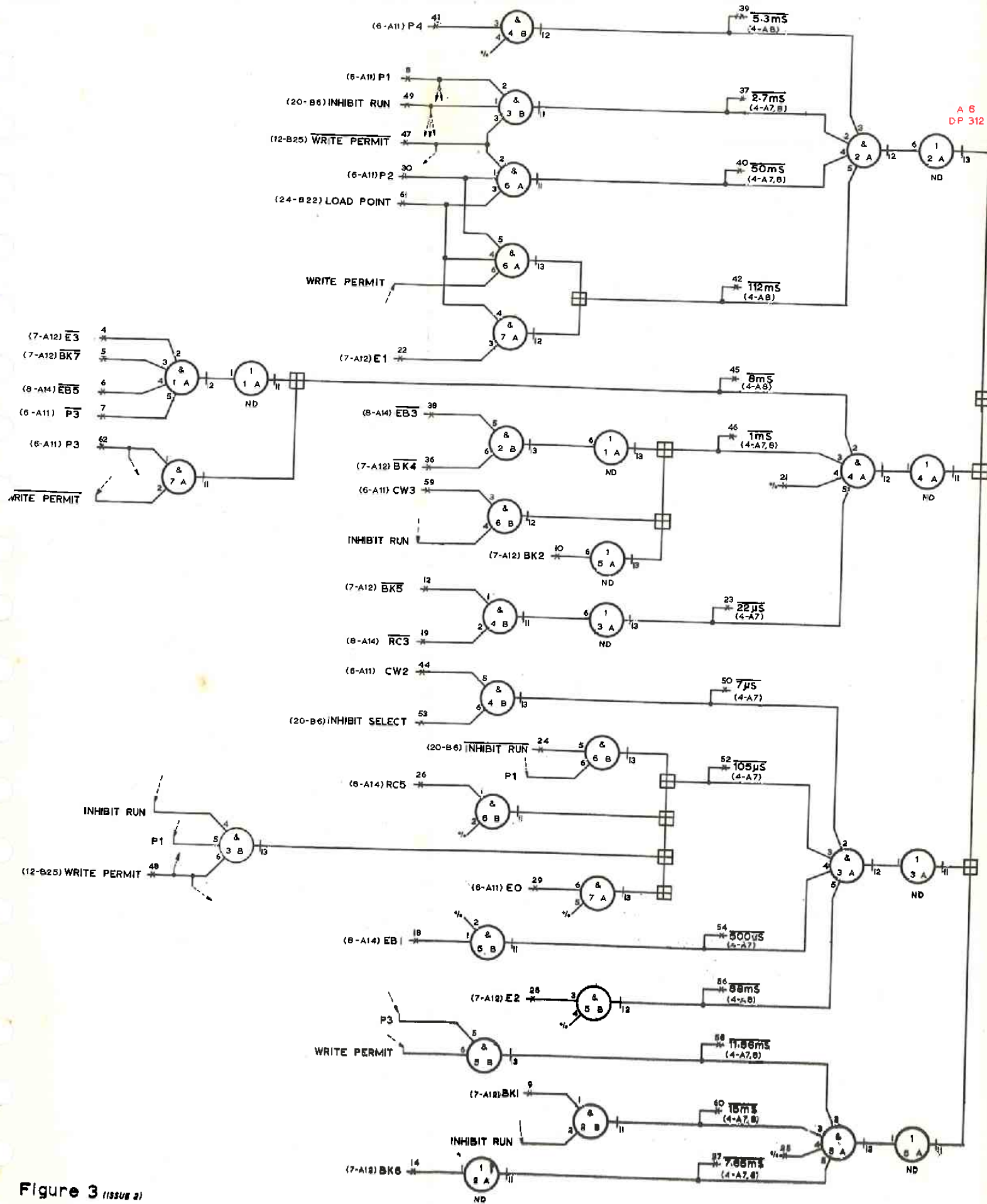
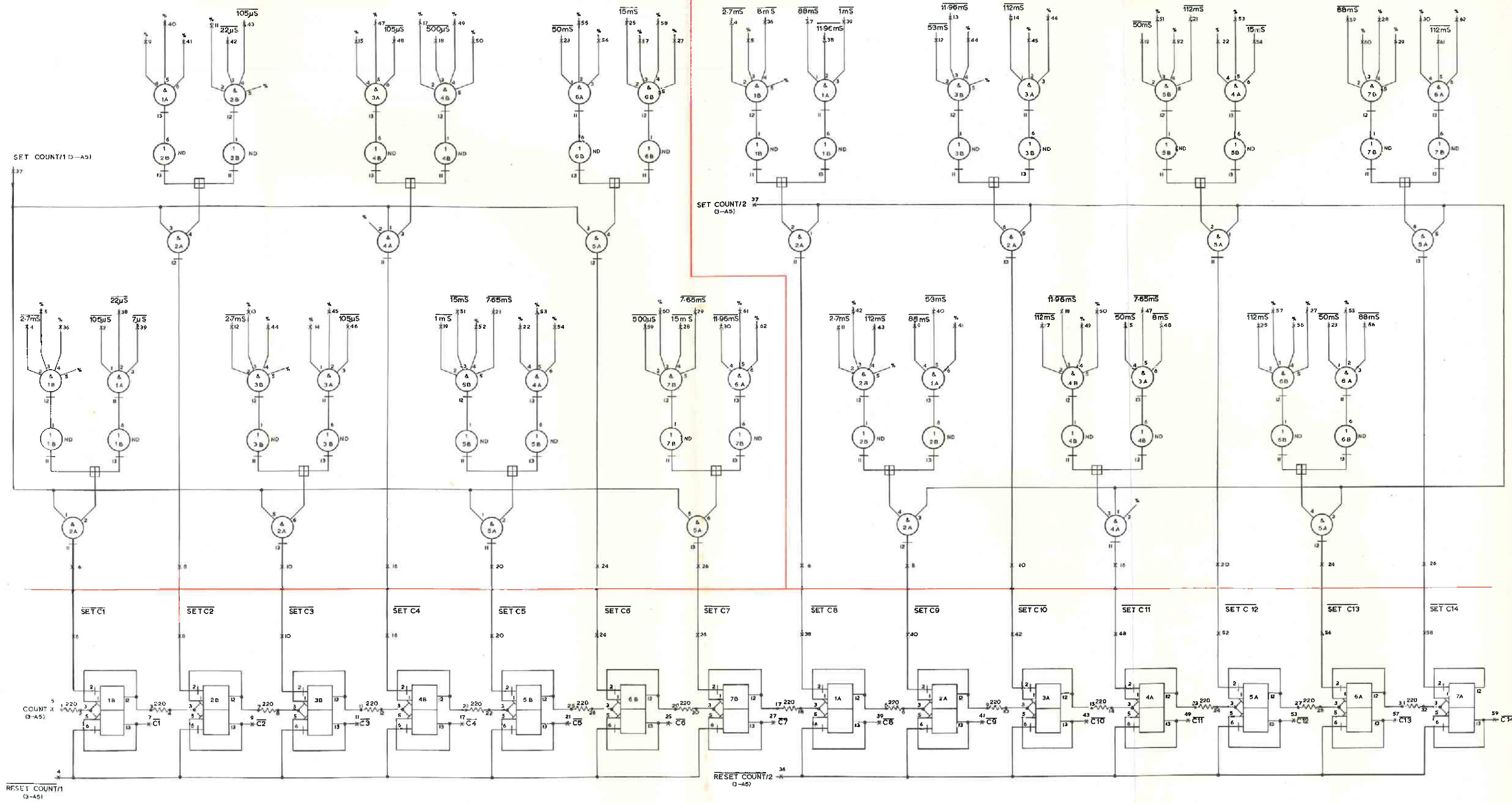

Figure 3 (ISSUE 2)

MAIN COUNTER CONTROL AND COUNT ZERO DECODE



MAIN COUNTER.

Figure 4 (ISSUE 2)

DP320
A24

DP319
A23

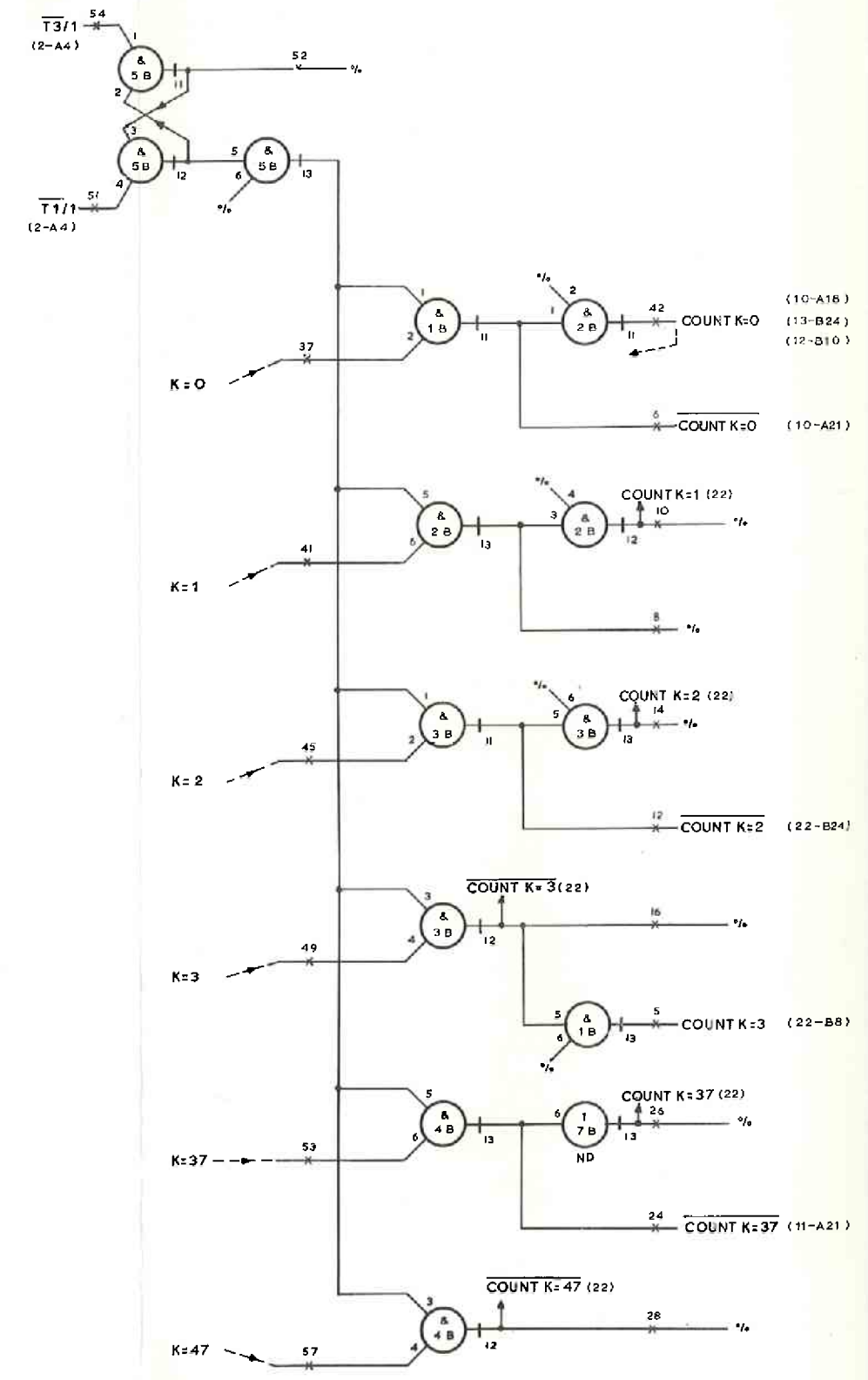
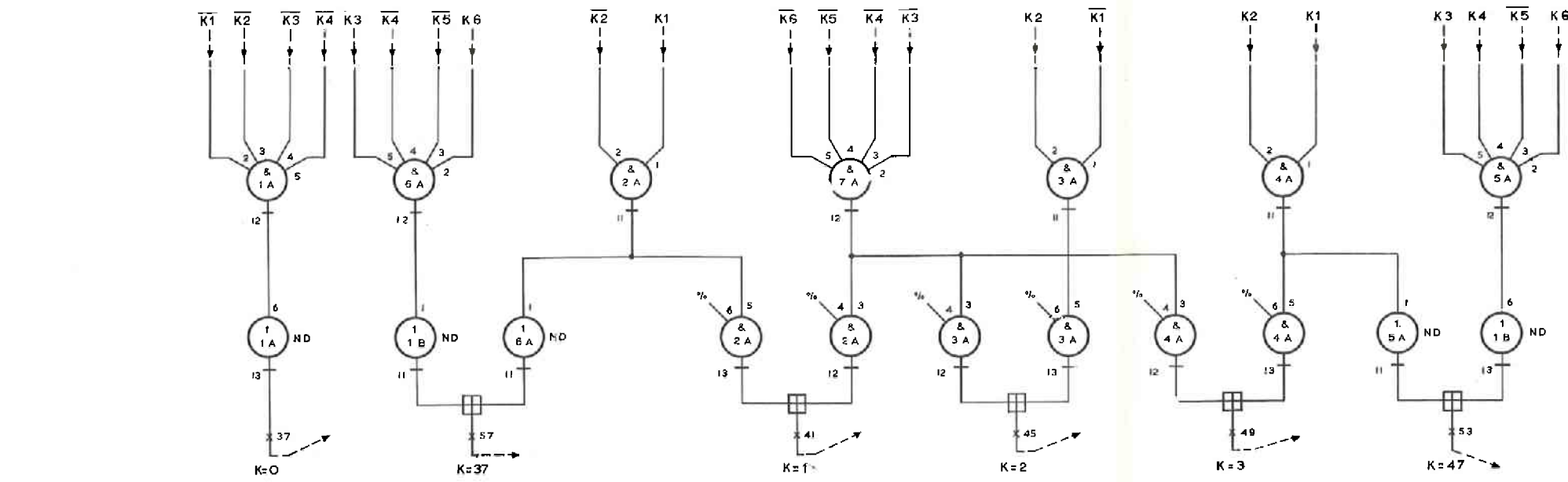
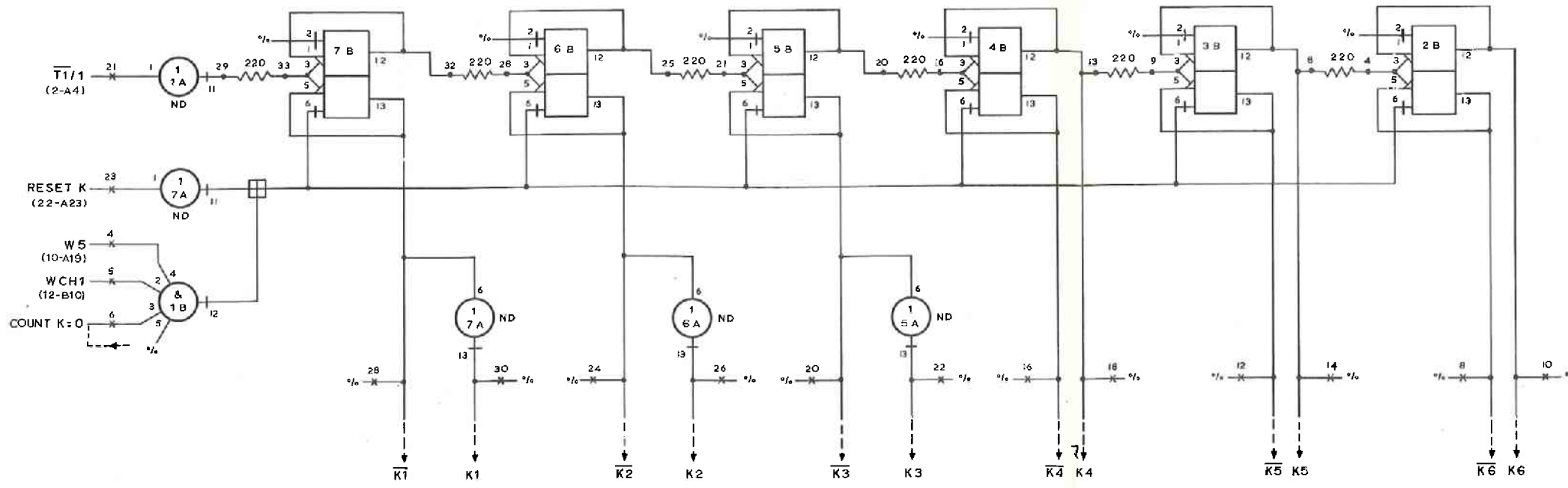

K COUNTER AND DECODE

Figure 5 (ISSUE 2.1)

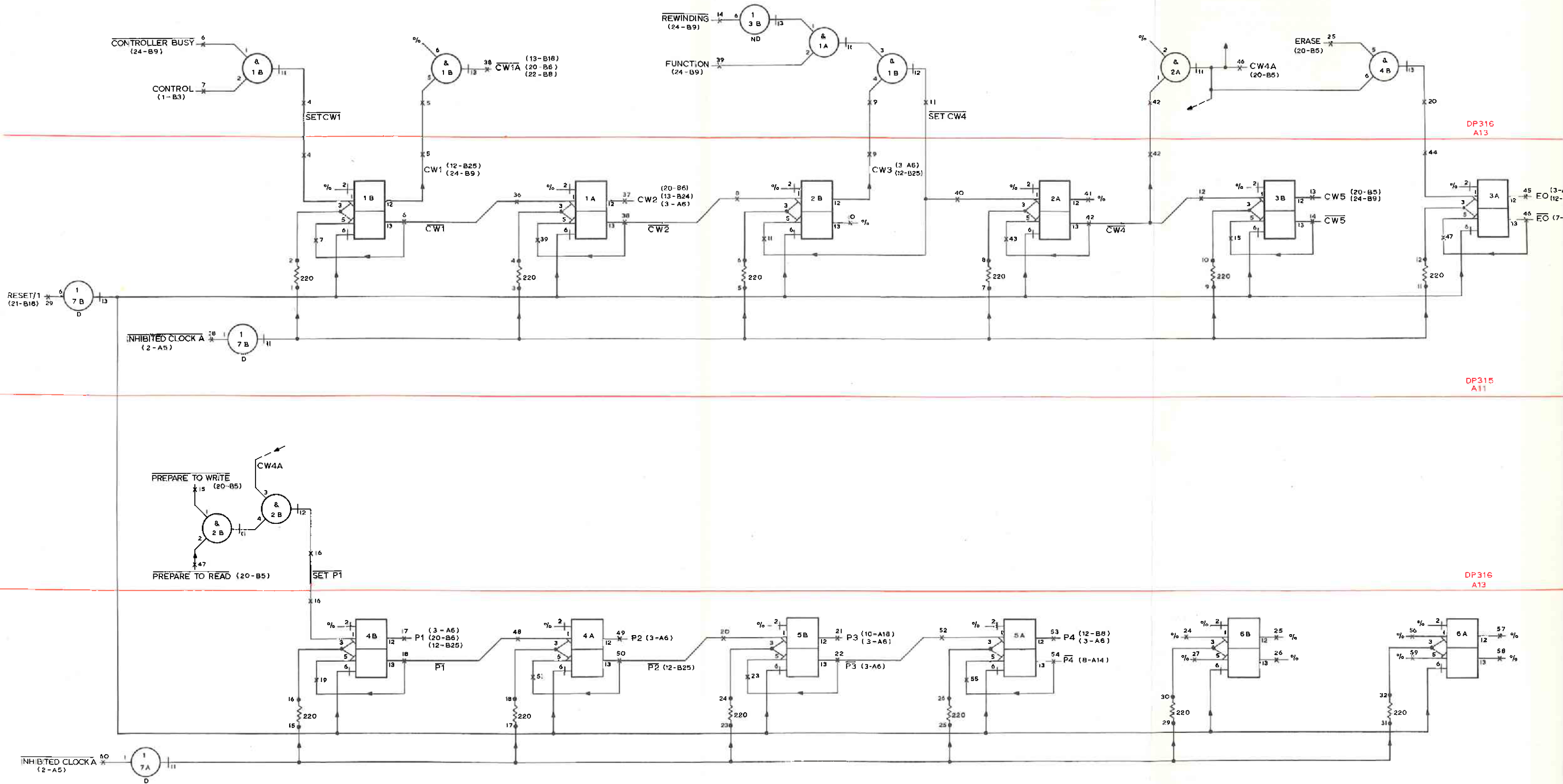

CONTROL WRITE AND PREPARE SEQUENCE CONTROL

Figure 6 (ISSUE)

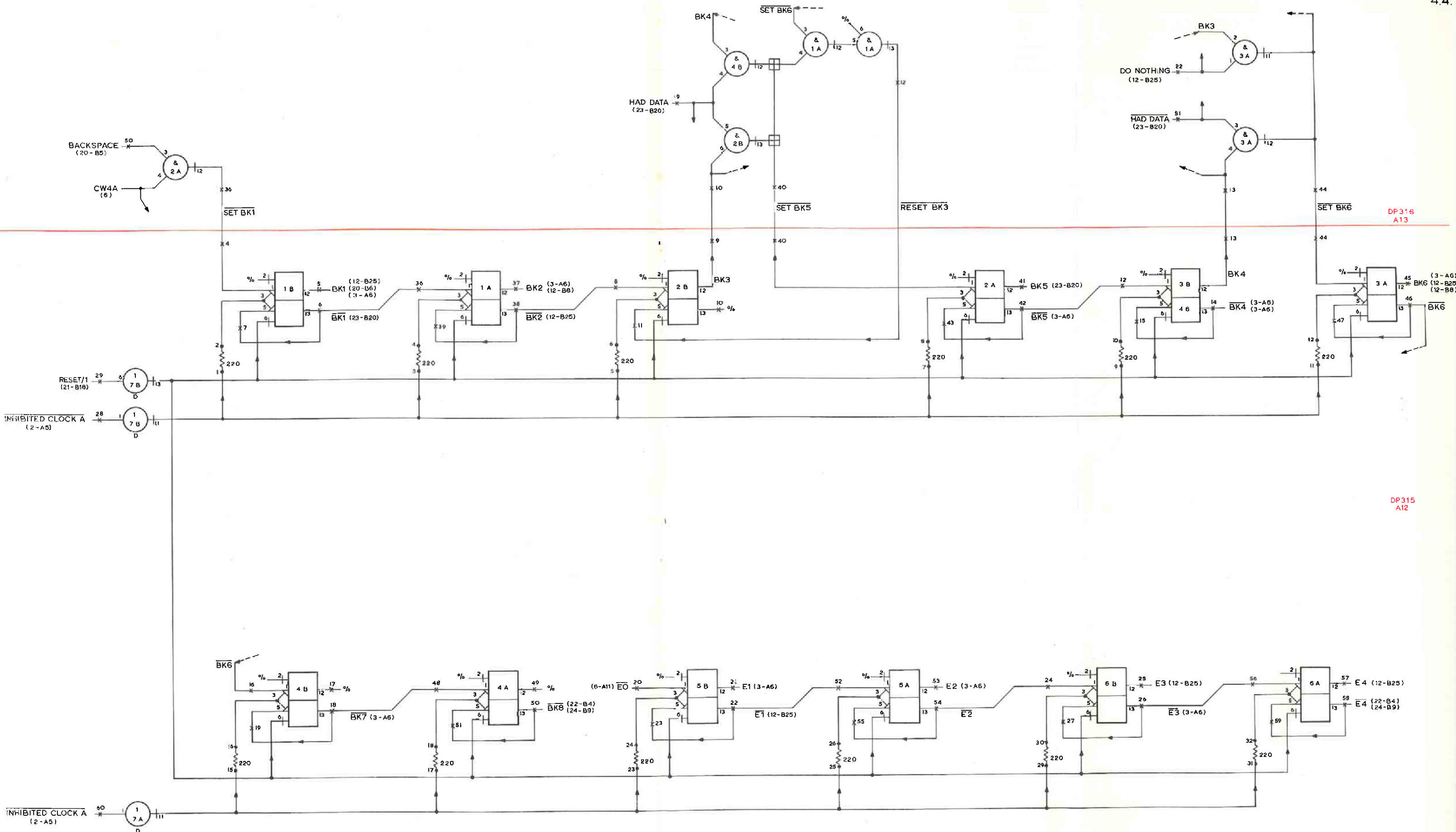

BACKSPACE AND ERASE (E1-E4) SEQUENCE CONTROL

Figure 7 (ISSUE 2)

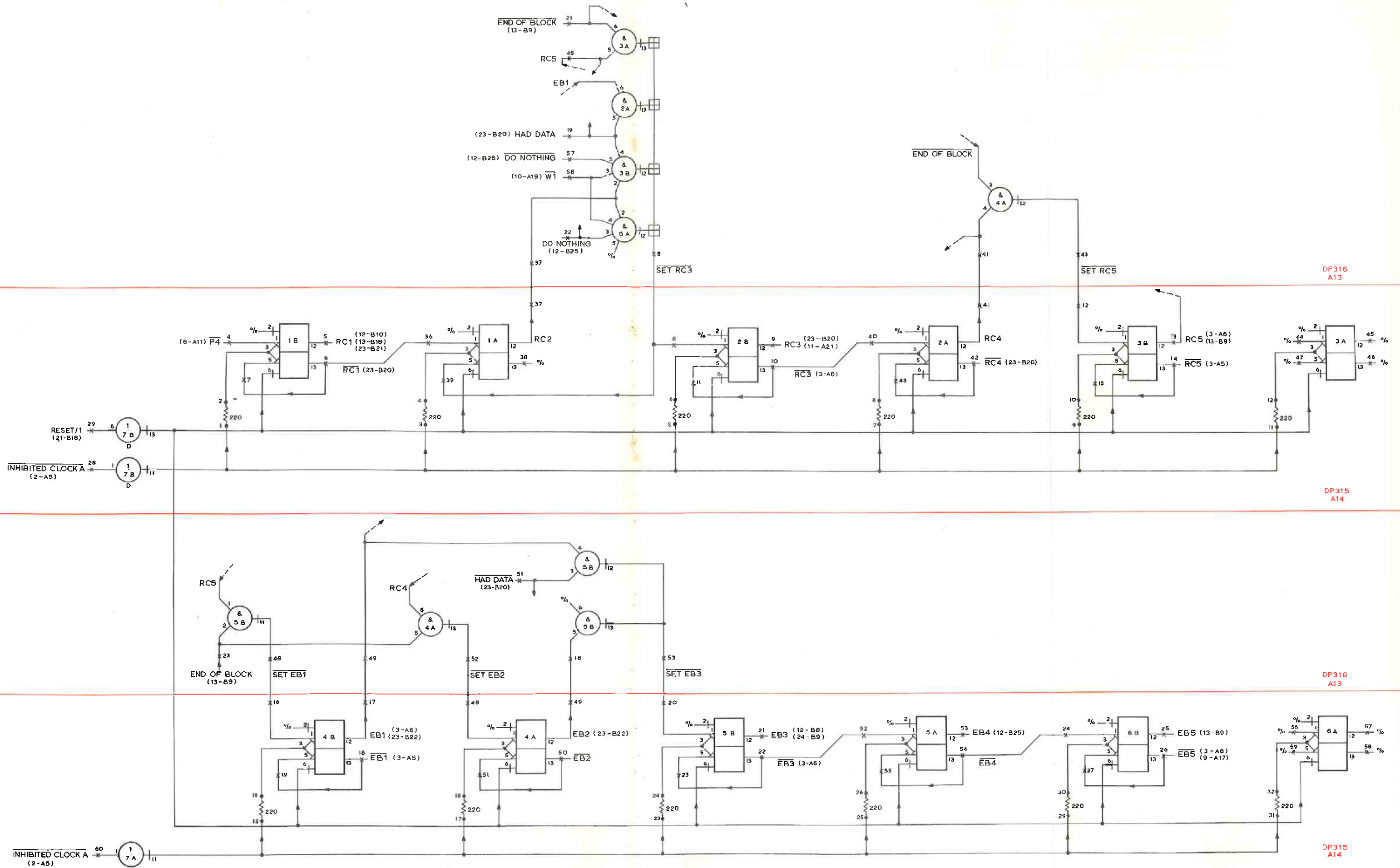

READ CHECK AND END OF BLOCK (EB1-5) SEQUENCE CONTROL.

Figure 8 (ISSUE 2)

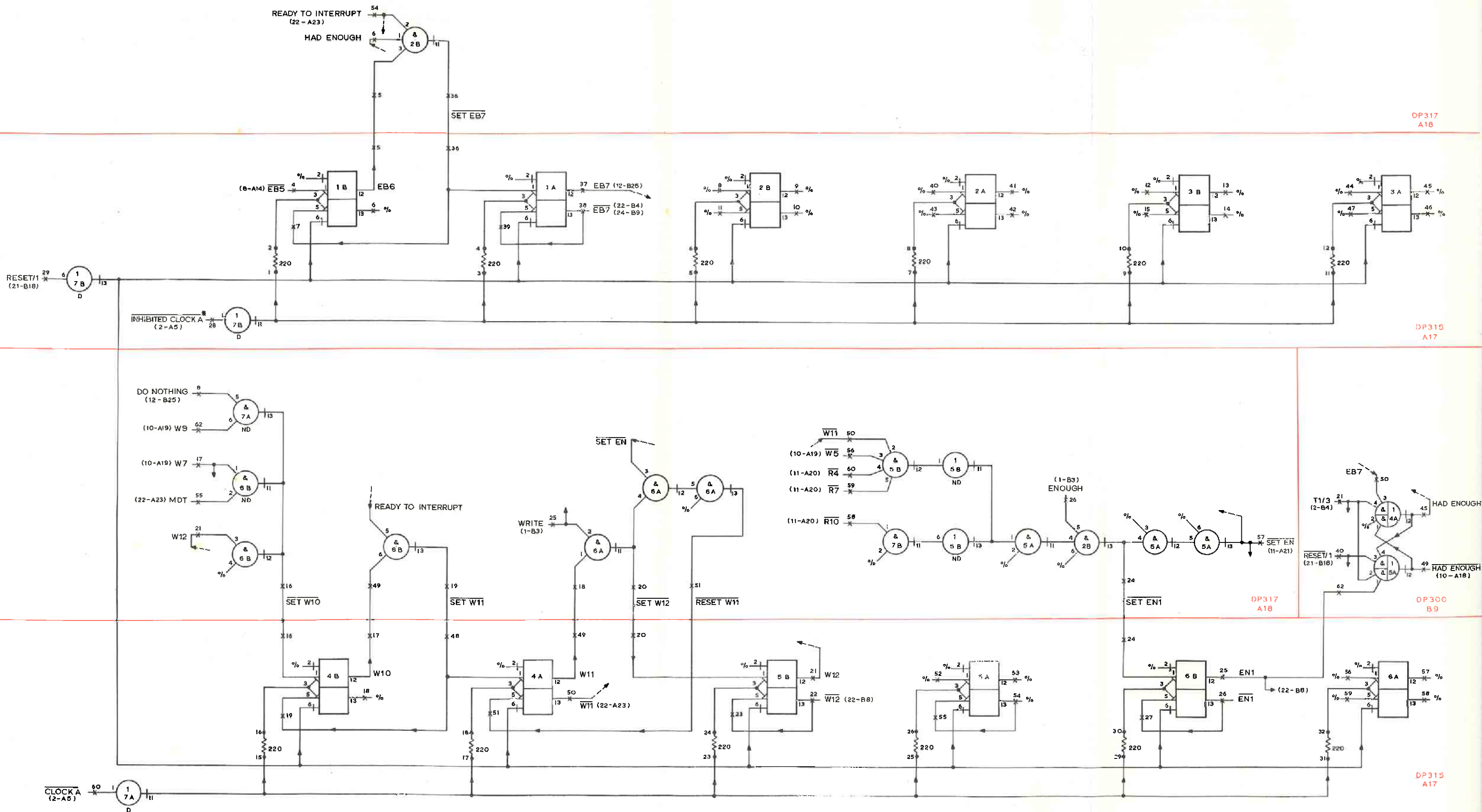

END OF BLOCK (EB6,7), WRITE (W10-12) AND ENOUGH SEQUENCE CONTROL.

Figure 9 (ISSUE 2)

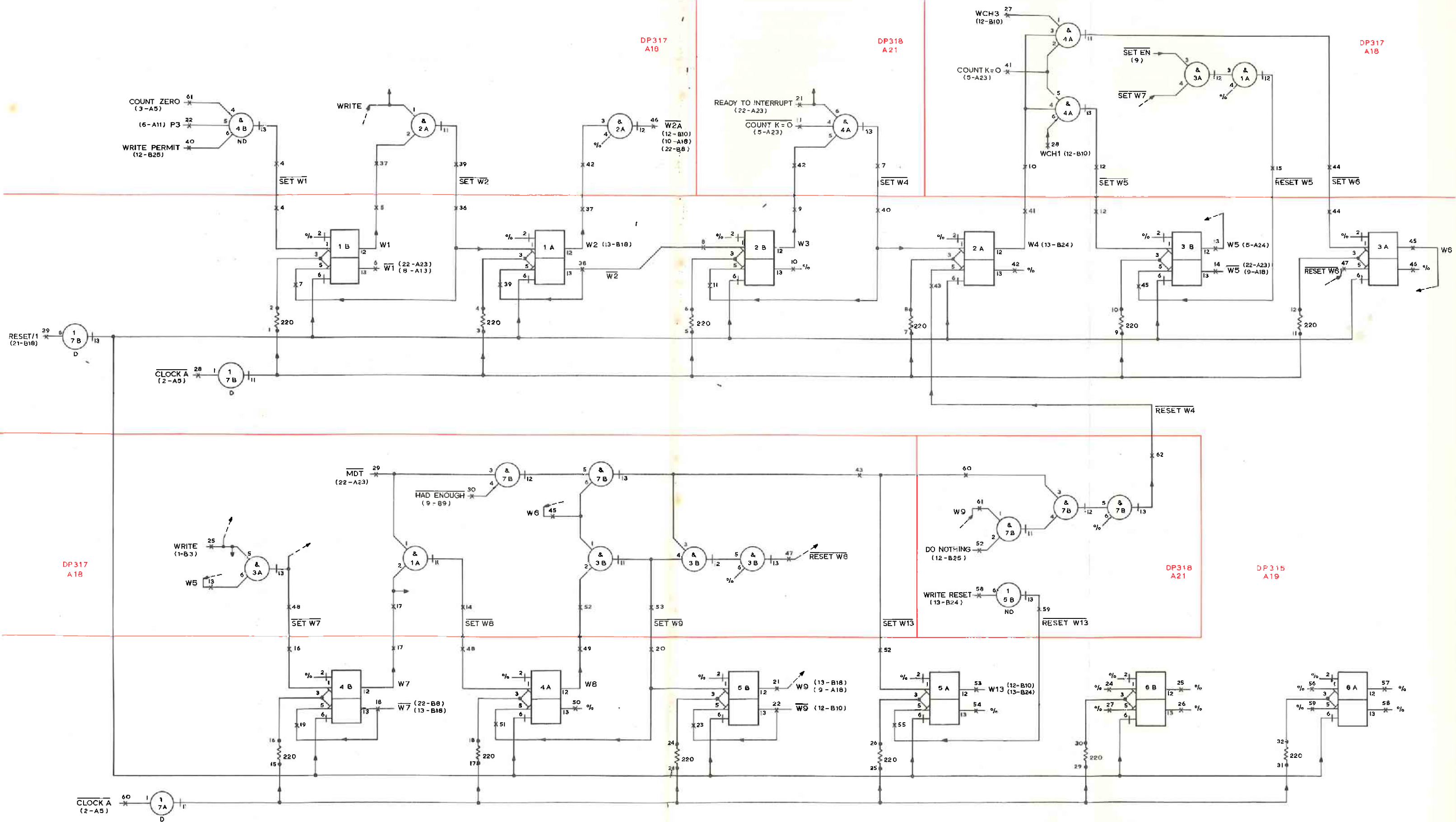

WRITE SEQUENCE (W1-9, W13) CONTROL

Figure 10 (ISSUE 2)

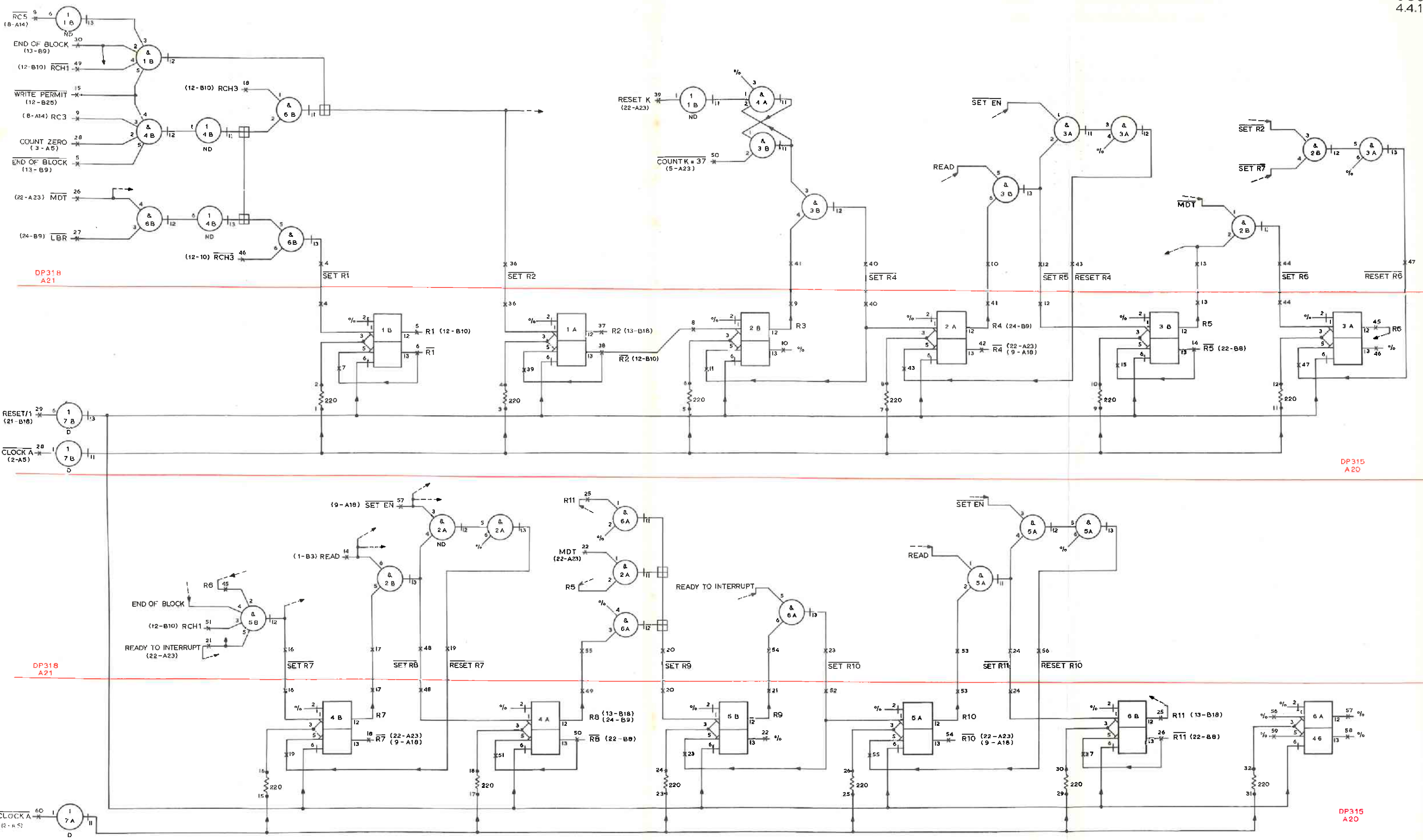

READ SEQUENCE CONTROL

Figure 11 (ISSUE 2)

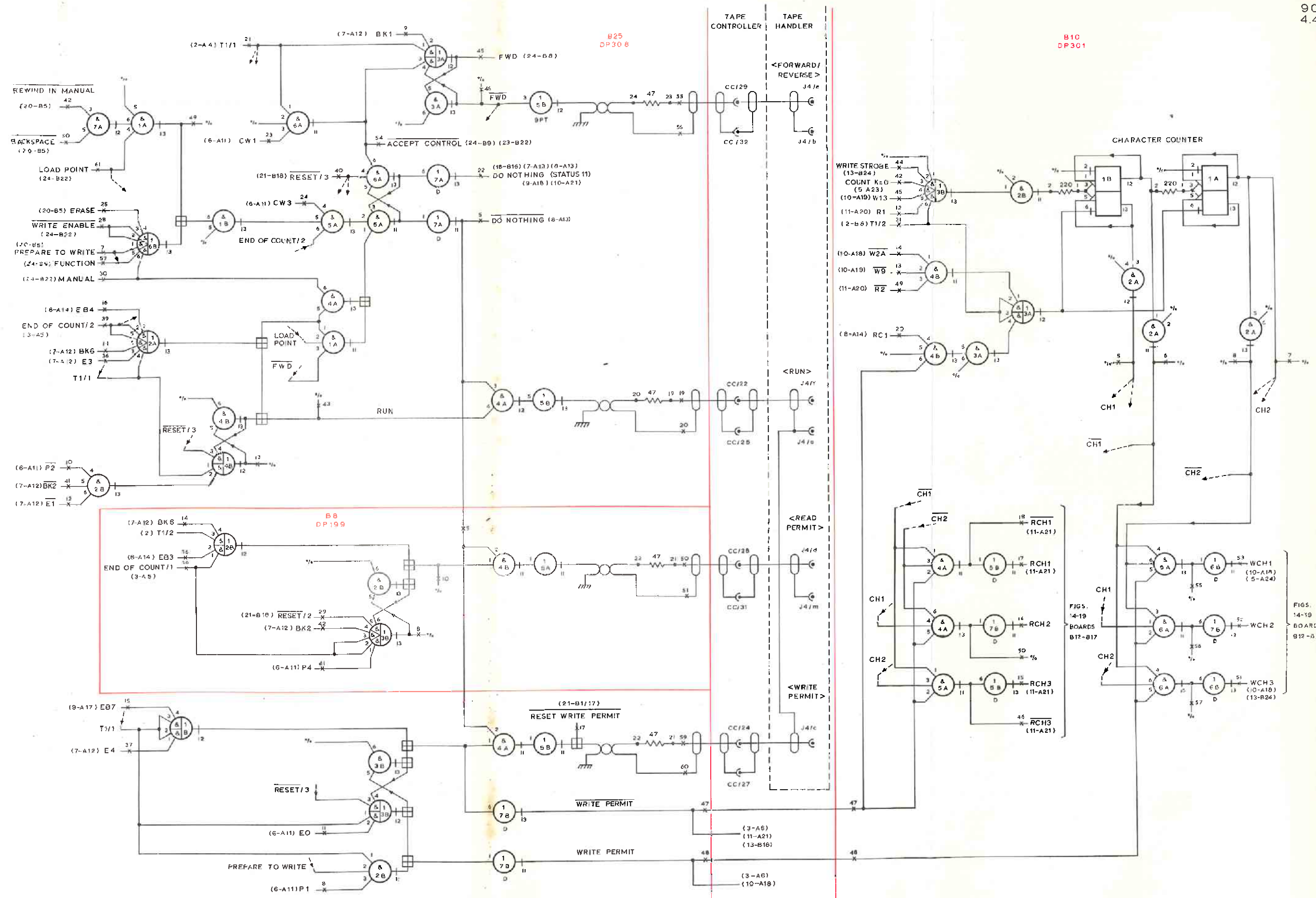

RUN FORWARD/REVERSE, READ AND WRITE PERMIT AND CHARACTER COUNTER

Figure 12 (ISSUE 2)

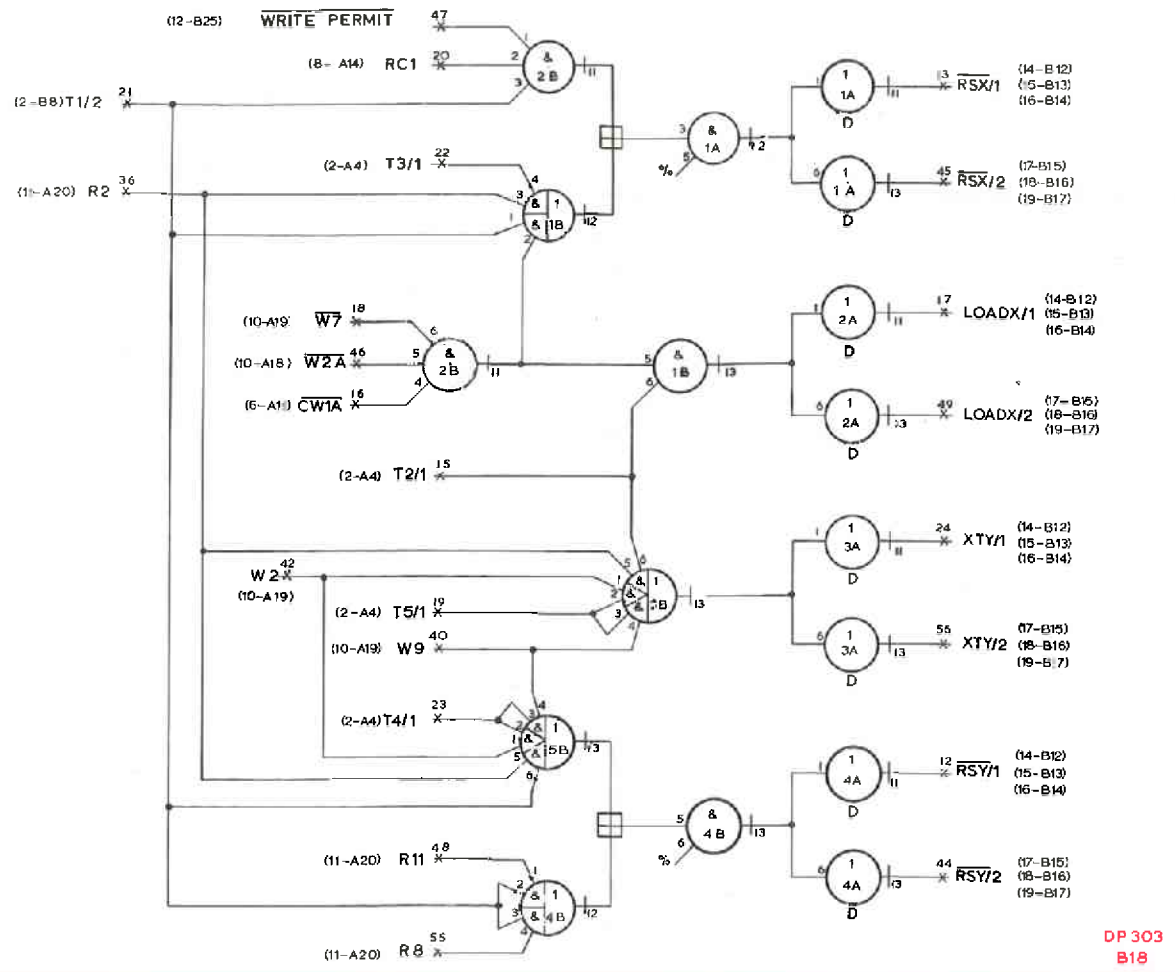

DP 303
B18

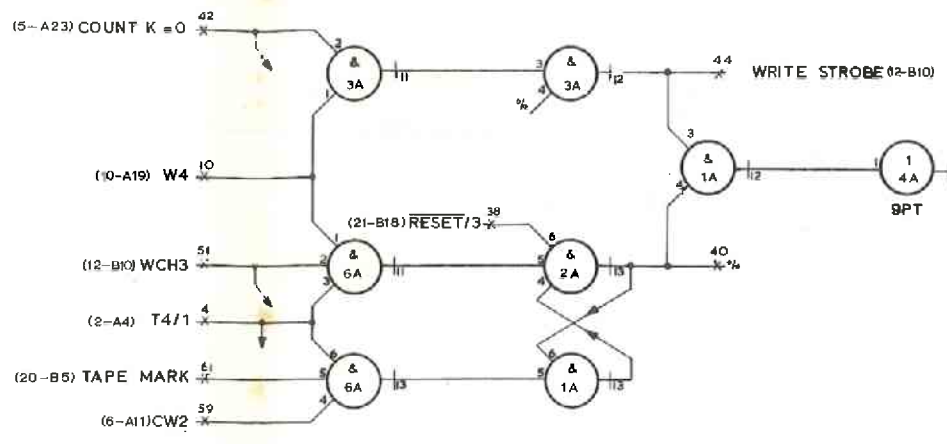

DP 307
B24

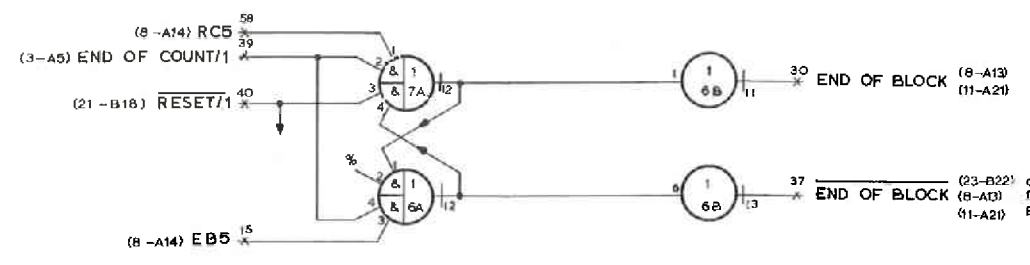

DP 300
B9

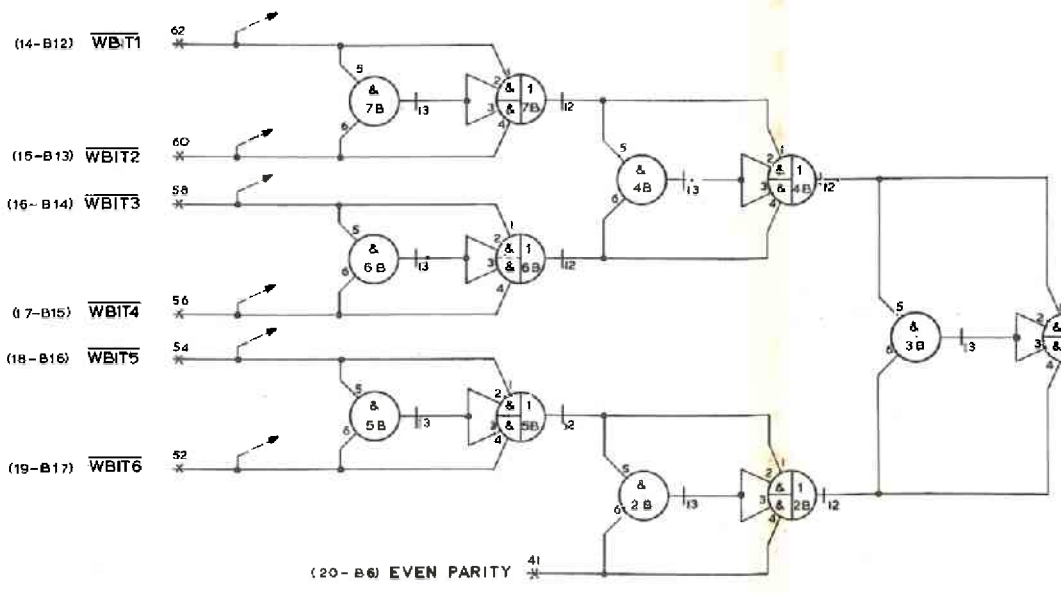

TAPE CONTROLLER

TAPE HANDLER

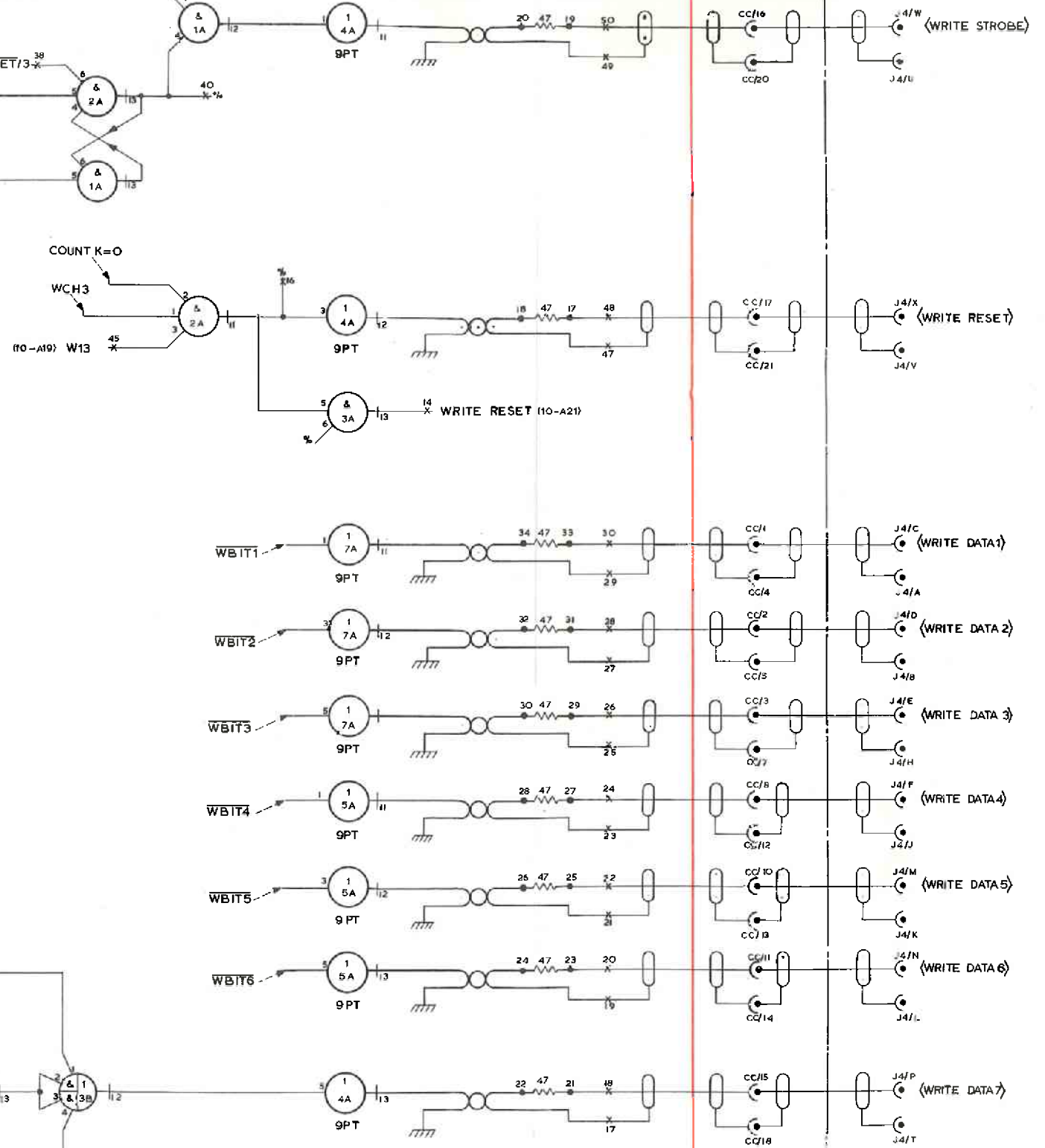

WRITE DATA TRANSFER.

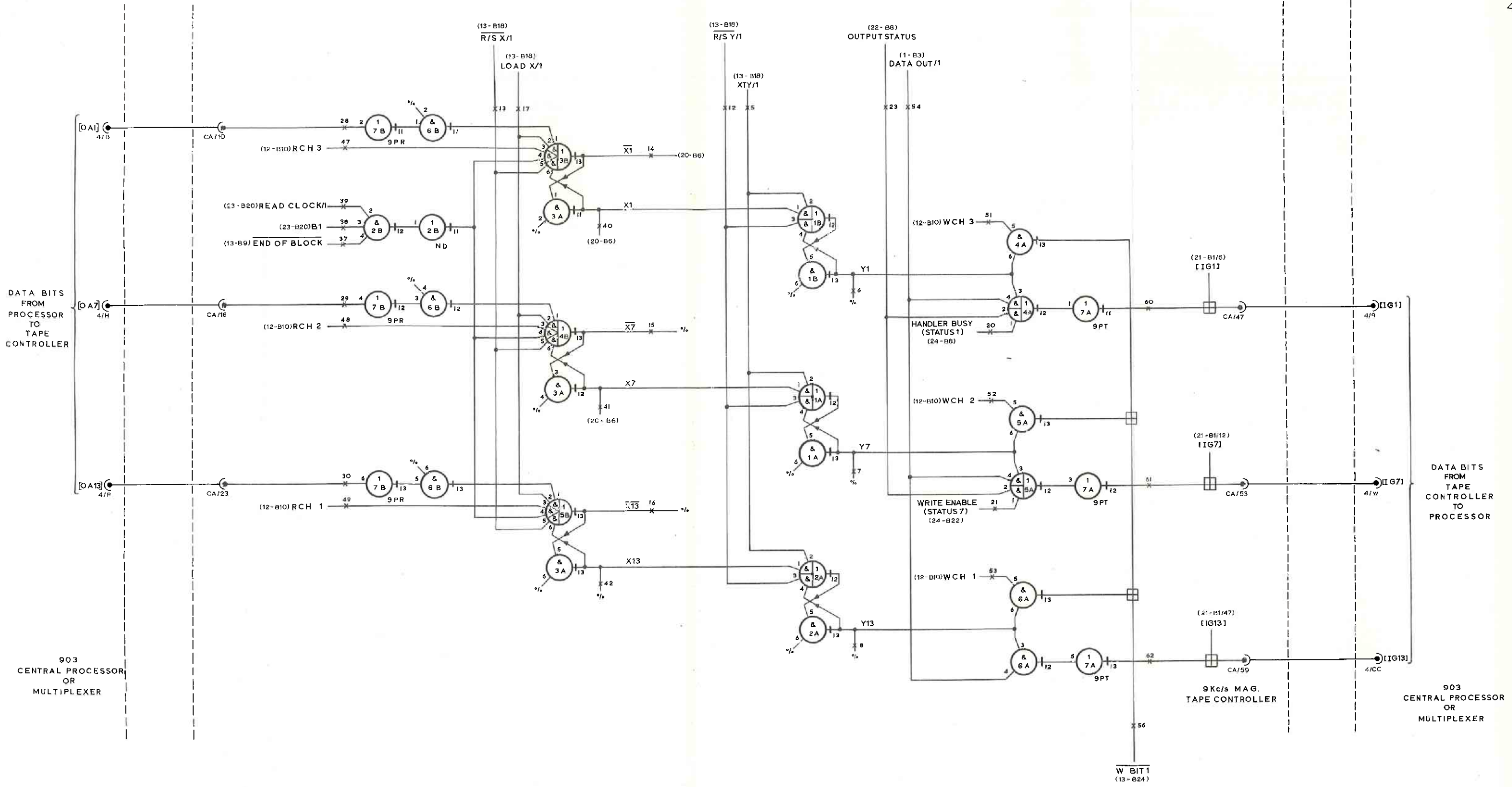

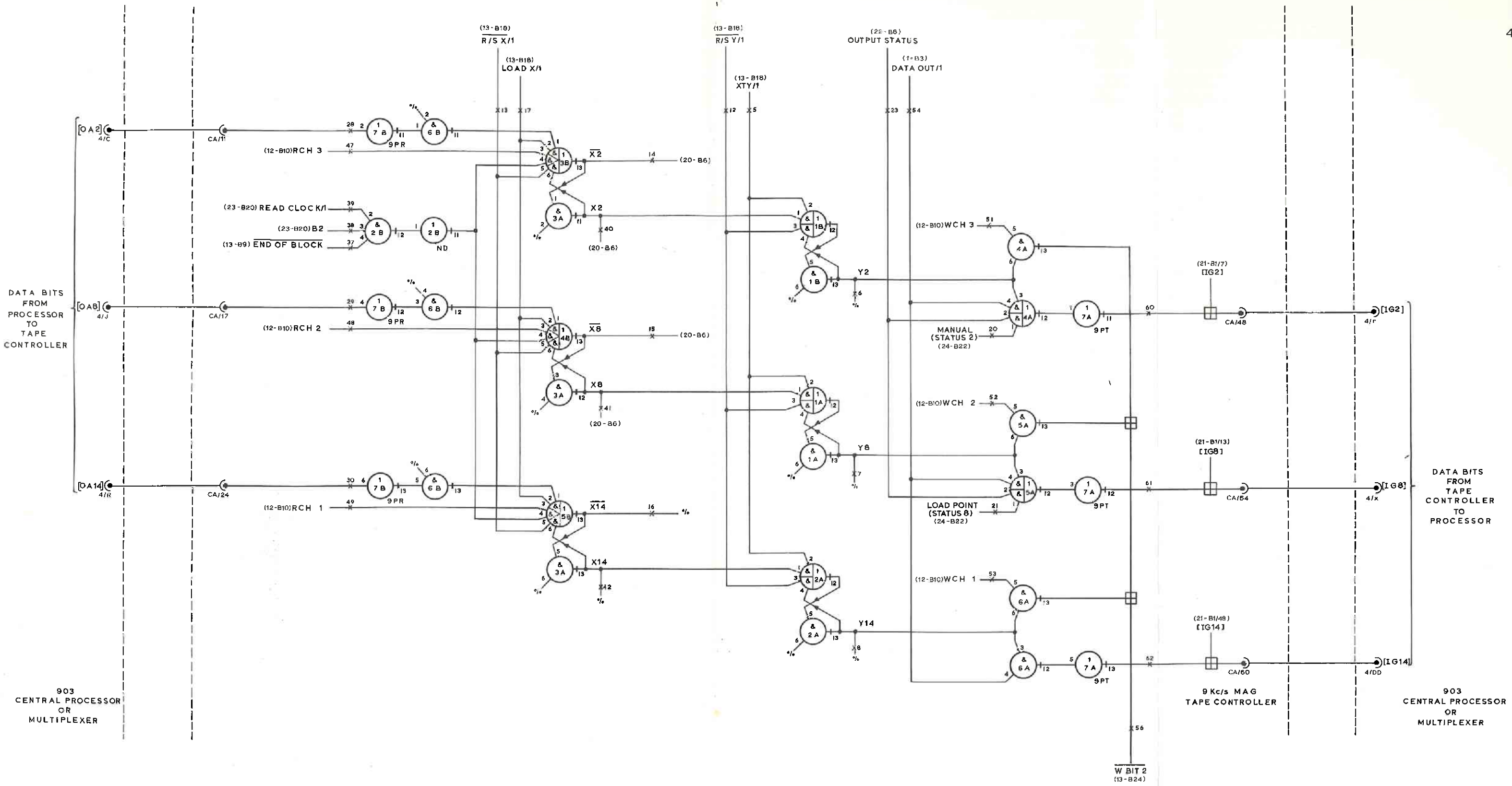

903
CENTRAL PROCESSOR
OR
MULTIPLEXER

903
CENTRAL PROCESSOR
OR
MULTIPLEXER

9 Kc/s MAG
TAPE CONTROLLER

X AND Y REGISTERS - BITS 2,8,14.(B13-DP302)

Figure 15 (ISSUE 2)

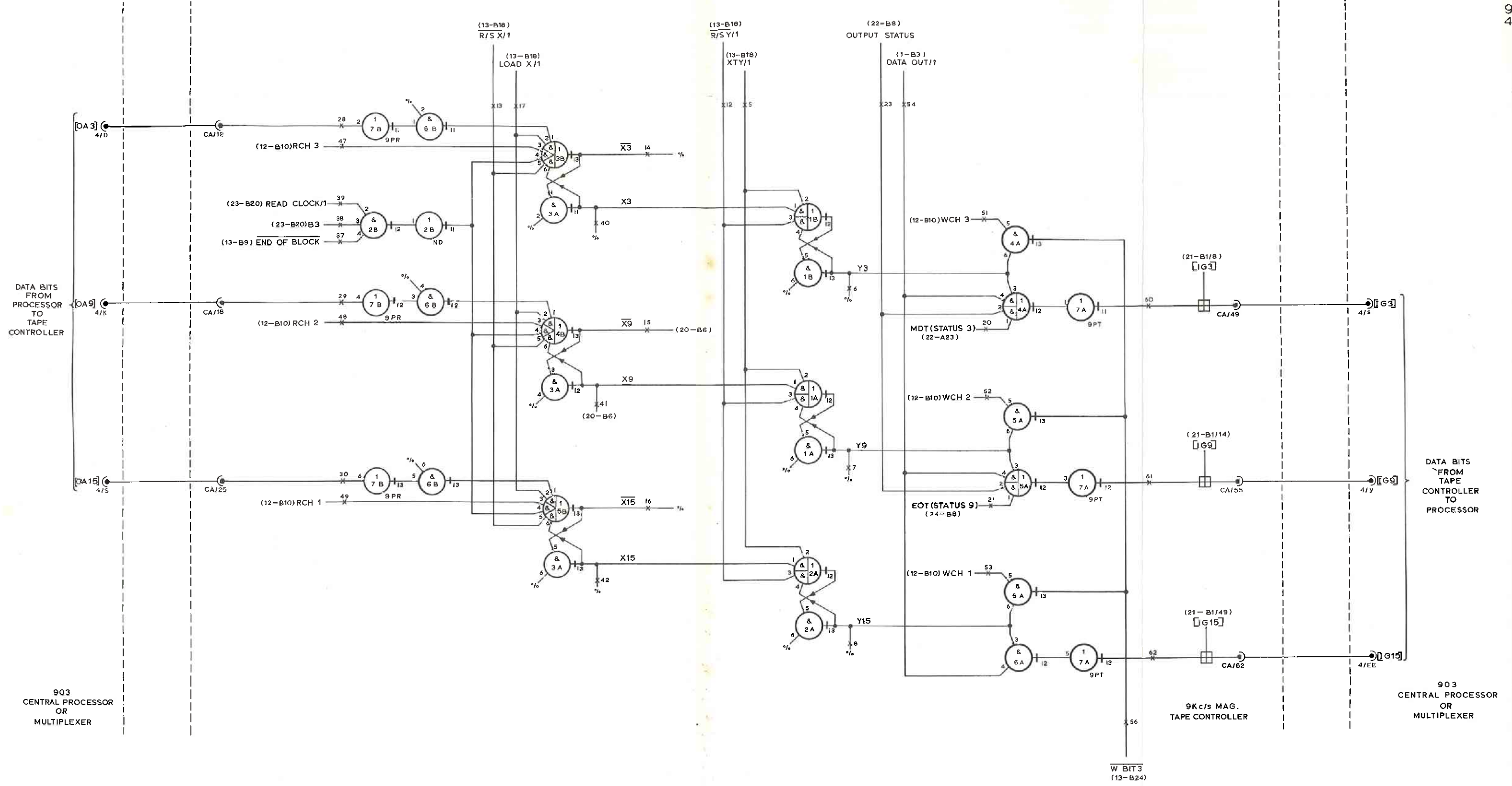

X AND Y REGISTERS - BITS 3, 9, 15.(B14-DP302)

Figure 16 (ISSUE 2)

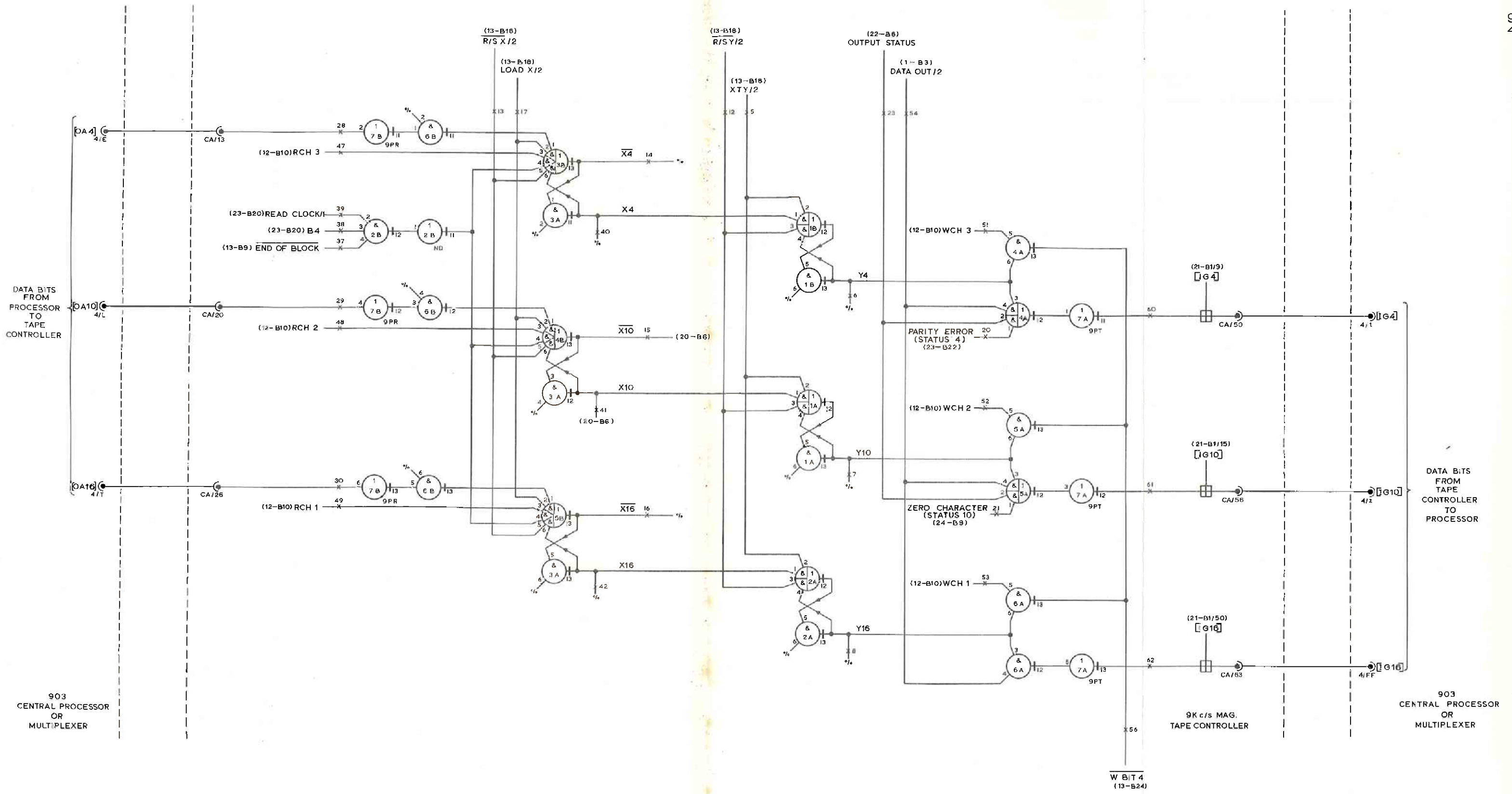

X AND Y REGISTERS - BITS 4, 10, 16. (B15-DP302)

Figure 17 (ISSUE 2)

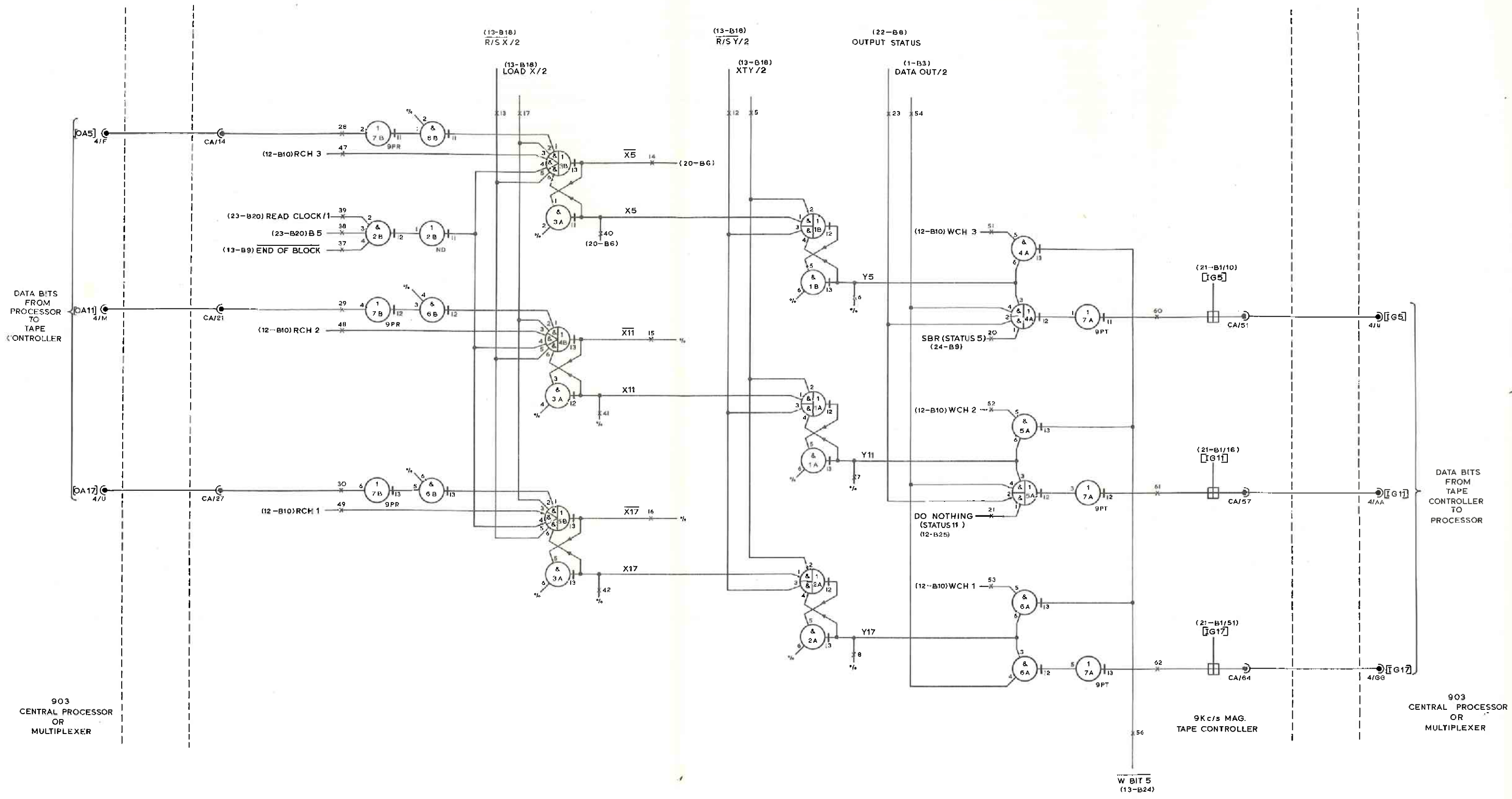

X AND Y REGISTERS -BITS 5, 11, 17(B16-DP302)

Figure 18 (ISSUE 2)

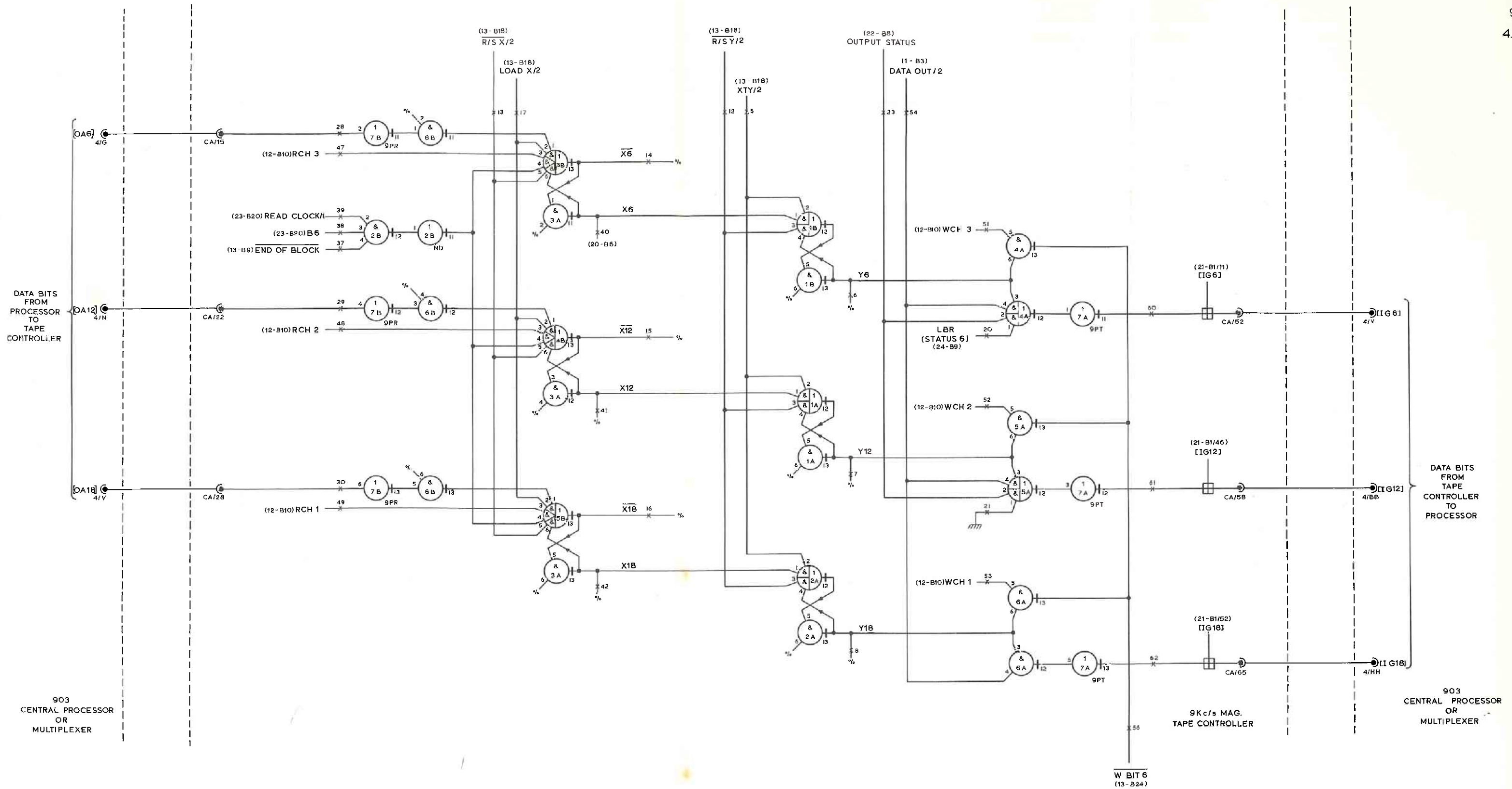

X AND Y REGISTERS — BITS 6,12,18(B17-DP302)

Figure 19 (ISSUE 2)

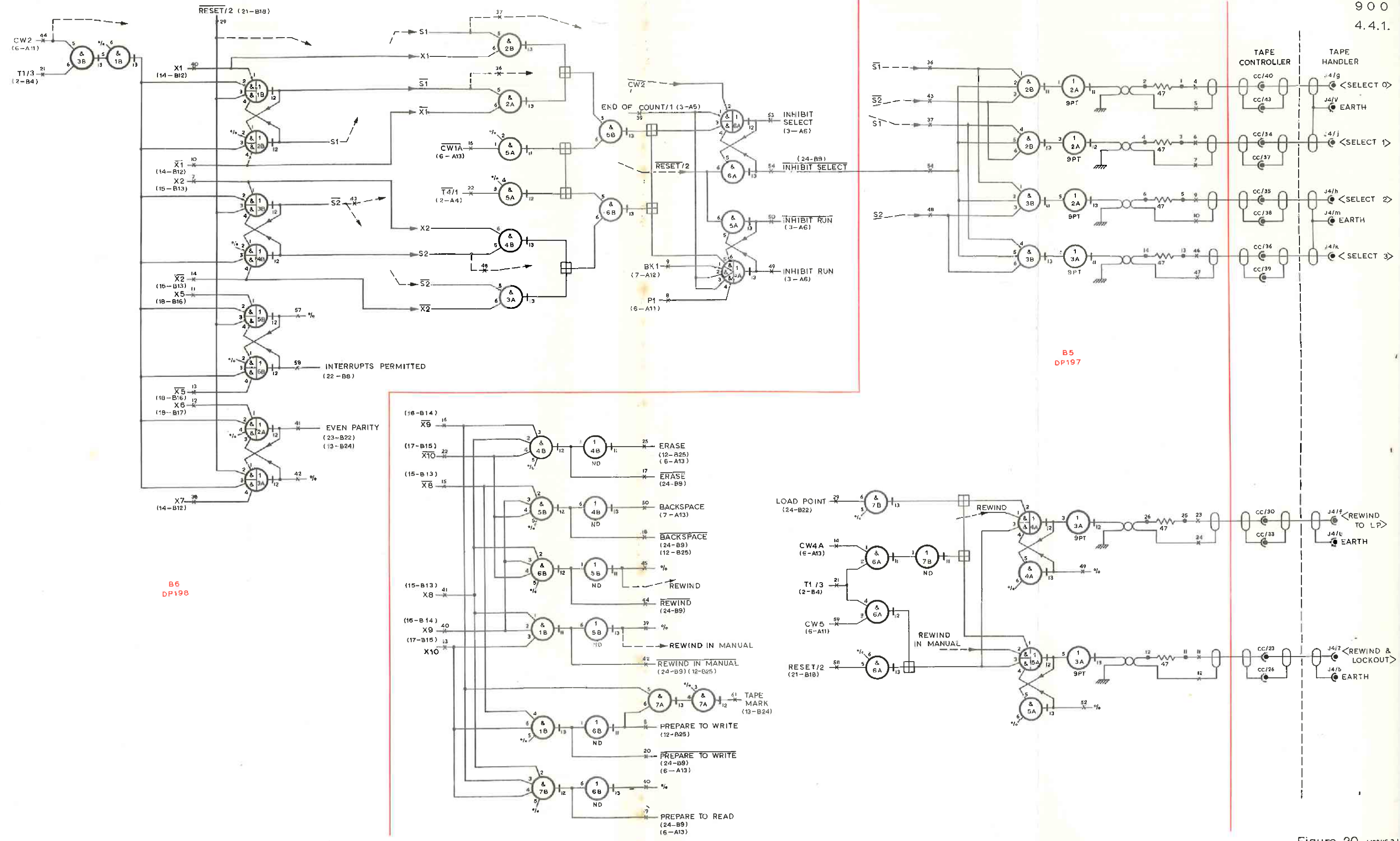

CONTROL WORD DECODE AND REWIND CONTROL

Figure 20 (ISSUE 2)

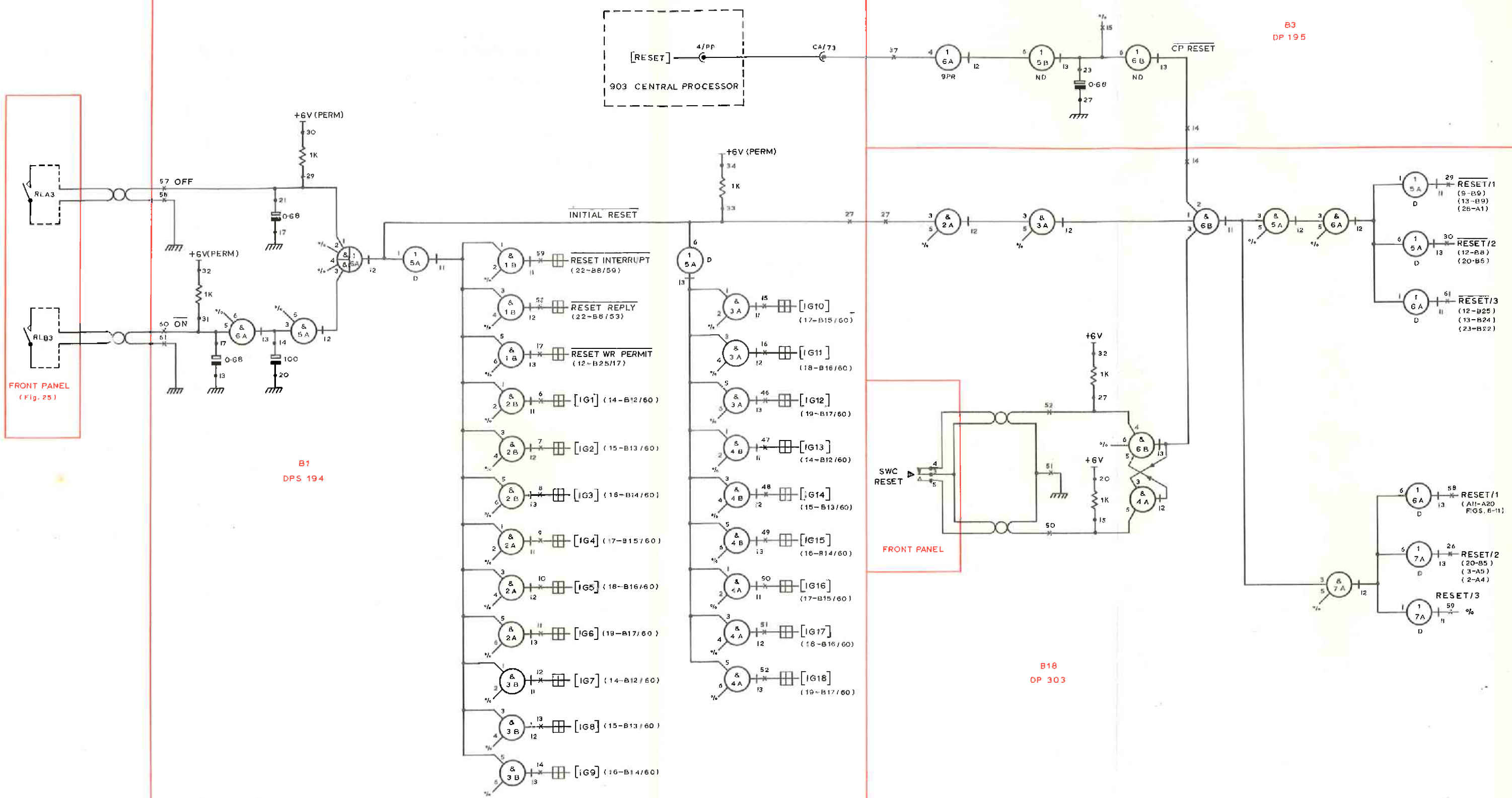

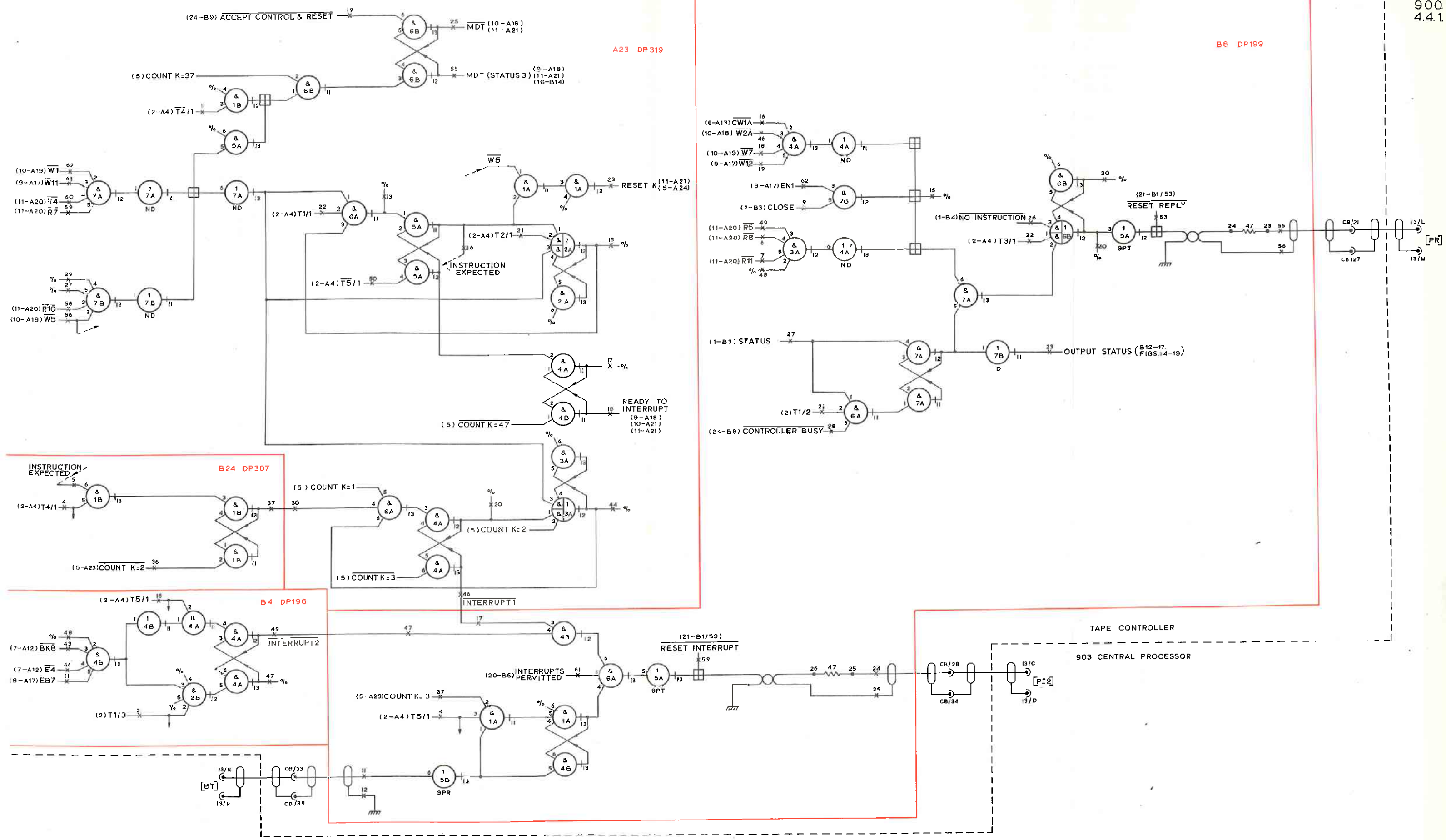

MDT (STATUS 3), REPLY AND INTERRUPT.

Figure 22 (ISSUE 2)

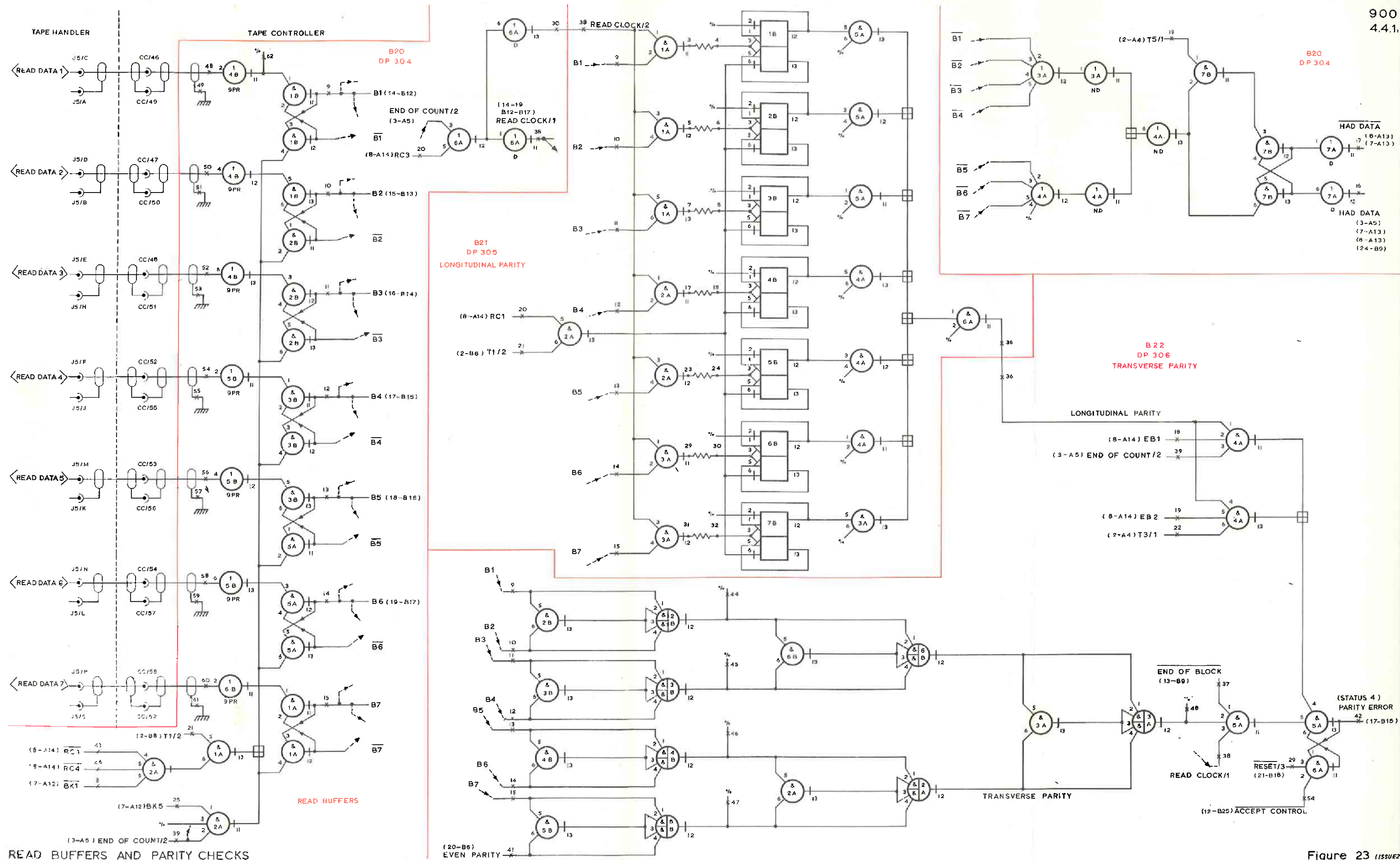

READ BUFFERS AND PARITY CHECKS

Figure 23 (ISSUE 2)

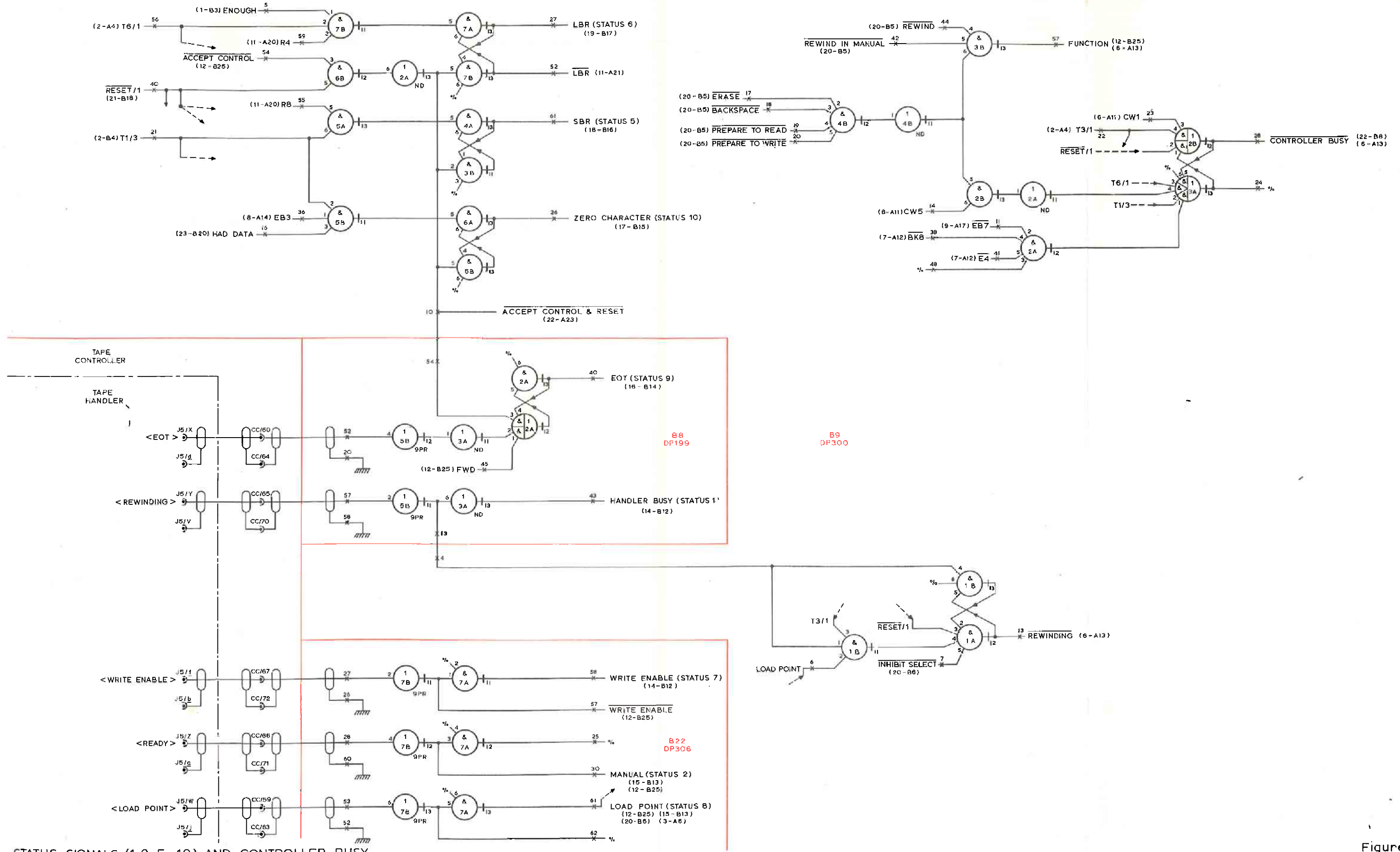

STATUS SIGNALS (1,2, 5- 10) AND CONTROLLER BUSY

Figure 24 (ISSUE 2)

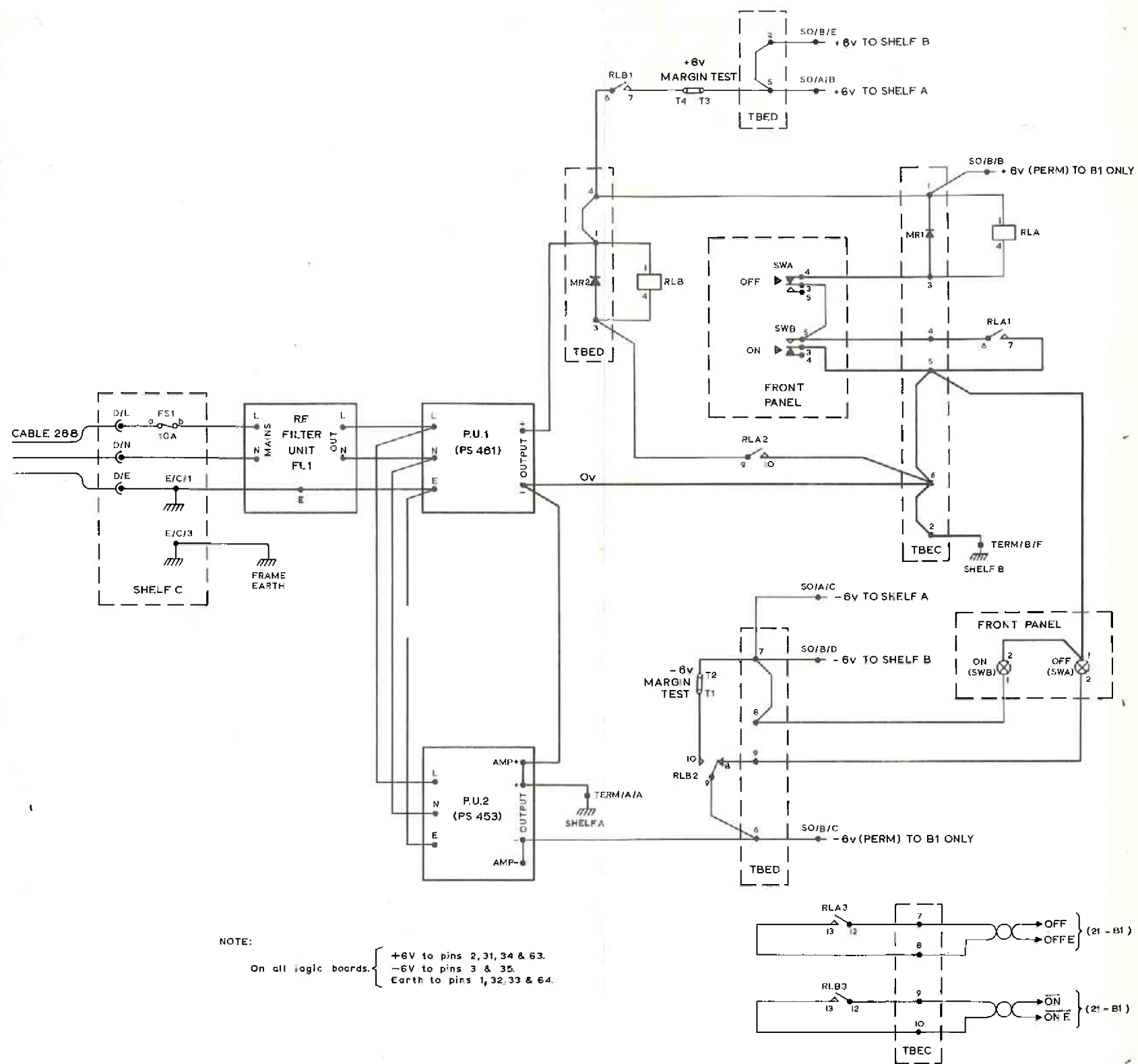

POWER SUPPLY SWITCHING

Figure 25 (ISSUE 2)

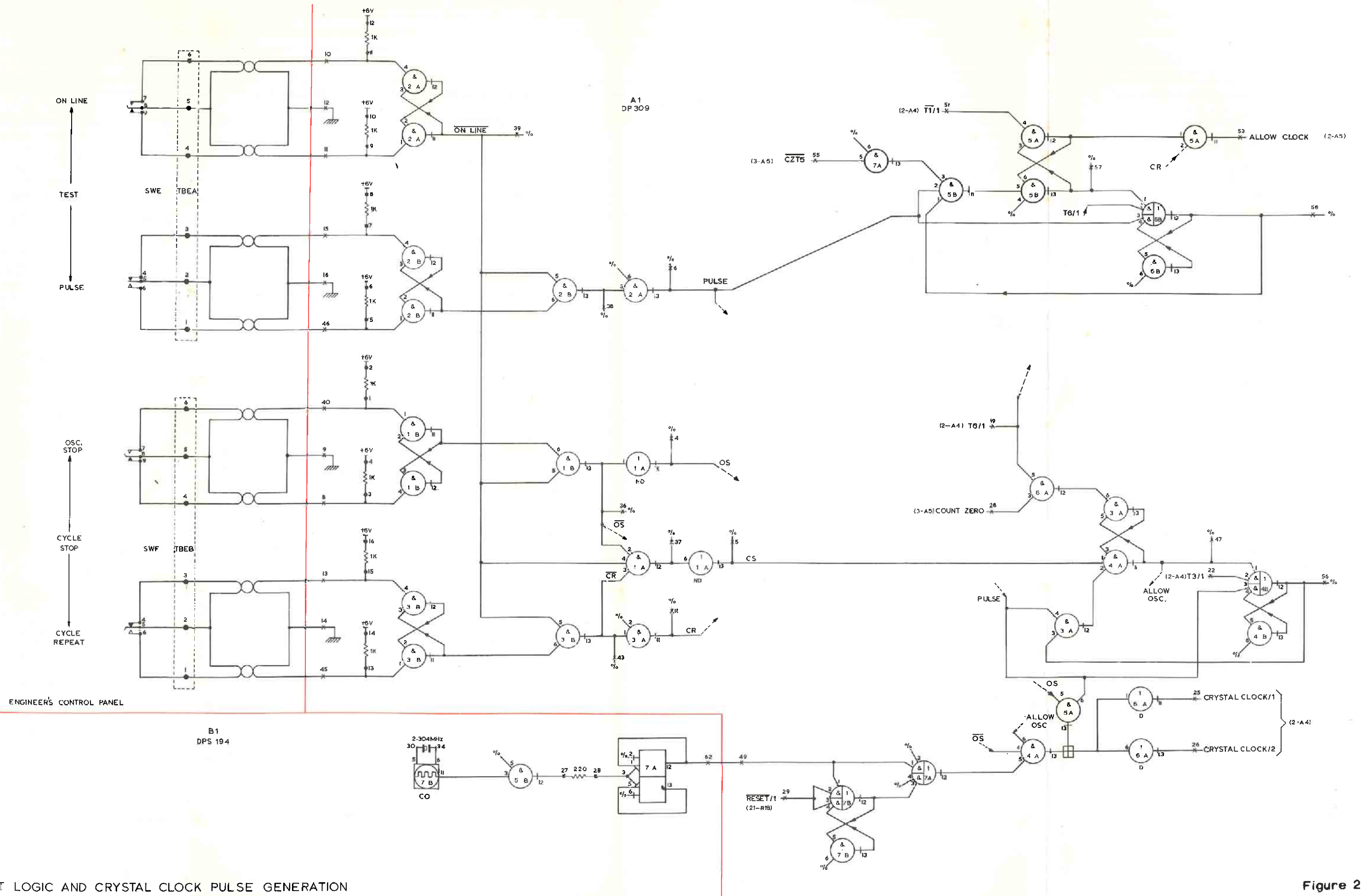

TEST LOGIC AND CRYSTAL CLOCK PULSE GENERATION

Figure 26 (ISSUE 2)